

GP6K7.5PV-US-GE Hybrid PV Inverter

USER MANUAL



Table Of Contents

1.	Introduction	1
2.	Important Safety Warning.....	2
3.	Unpacking & Overview	4
	3-1. Packing List.....	4
	3-2. Product Overview	4
4.	Installation	5
	4-1. Precaution	5
	4-2. Selecting Mounting Location	5
	4.3. Mounting Unit	5
5.	Grid (Utility) Connection	7
	5-1. Preparation	7
	5-2. Connecting to the AC Utility.....	7
6.	Generator Connection.....	8
	6-1. Preparation	8
	6-2. Connecting to the Generator Input.....	8
7.	PV Module (DC) Connection	9
8.	Battery Connection.....	12
9.	Load (AC Output) Connection.....	13
	9-1. Preparation	13
	9-2. Connecting to the AC output.....	13
10.	Communication.....	15
	10-1. Wi-Fi Connection	15
	10-2. Pin Assignment for RS-232 Communication Port	15
	10-3. Pin Assignment for BMS Communication Port	16
	10-4. Dry Contact Signal	16
11.	Commissioning	18
12.	Initial Setup.....	19
13.	Operation.....	32
	13-1. Interface.....	32
	13-2. LCD Information Define.....	32
	13-3. Touchable function keys	34
	13-4. Cold start button (located on the side of the inverter)	35
	13-5. LCD Setting.....	35
	13-5. Query Menu Operation	45
	13-6. Operation Mode & Display	50
14.	Charging Management	54
15.	Maintenance & Cleaning	56
16.	Trouble Shooting.....	57
	16-1. Warning List.....	57
	16-2. Fault Reference Codes.....	58
17.	Specifications	62
	Appendix I: Parallel Installation Guide.....	64
	Appendix II: The CT Operation Guide	72
	Appendix III: The Generator Operation Guide	78
	Appendix IV: Rapid Shutdown Operation.....	79
	Appendix V: AC Coupling Wiring and Operation	82

1. Introduction

1-1. System Overview

This hybrid PV inverter can provide power to connected loads by utilizing PV power, utility power and battery power.

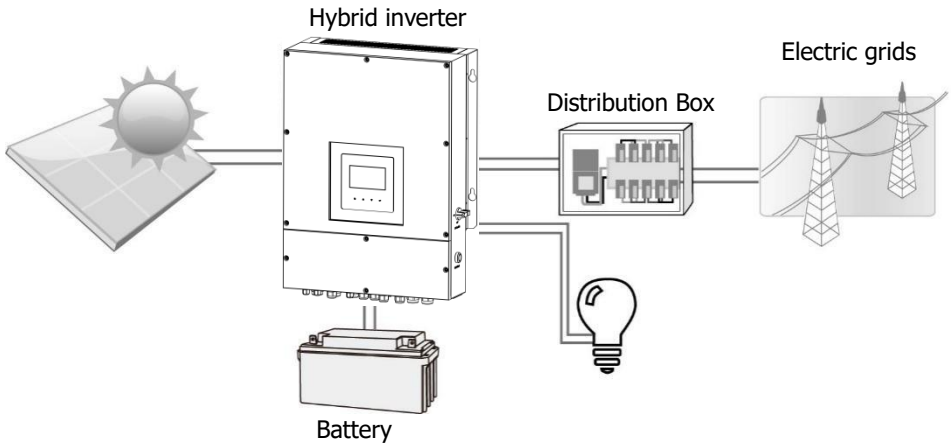







Figure 1 Basic hybrid PV System Overview

Depending on different power situations, this hybrid inverter is designed to generate continuous power from PV solar modules (solar panels), battery, and the utility. When MPP input voltage of PV modules is within acceptable range (see specification for the details), this inverter is able to generate power to feed the grid (utility) and charge battery. This inverter is only compatible with PV module types of single crystalline and poly crystalline. Do not connect any PV array types other than these two types of PV modules to the inverter. Do not connect the positive or negative terminal of the solar panel to the ground. See Figure 1 for a simple diagram of a typical solar system with this hybrid inverter.



2. Important Safety Warning













Before using the inverter, please read all instructions and cautionary markings on the unit and this manual. Store the manual where it can be accessed easily.

This manual is for qualified personnel. The tasks described in this manual may be performed by qualified personnel only.

Symbols used in Equipment Markings	
	Refer to the operating instructions
	Caution! Risk of danger
	Caution! Risk of electric shock
	Caution! Risk of electric shock. Energy storage timed discharge for 5 minutes.
	Caution! Hot surface
Conventions used in this Document	
WARNING!	Warnings identify conditions or practices that could result in personal injury;
CAUTION!	Cautions identify conditions or practices that could result in damaged to the unit or other equipment connected.

General Precautions

	WARNING! Before installing and using this inverter, read all instructions and cautionary markings on the inverter and all appropriate sections of this guide.
	WARNING! Normally grounded conductors may be ungrounded and energized when a ground fault is indicated.
	WARNING! This inverter is heavy. It should be lifted by at least two people.

 	<p>CAUTION! Authorized service personnel should reduce the risk of electrical shock by disconnecting AC, DC and battery power from the inverter before attempting any maintenance, cleaning or working on any circuits connected to the inverter. Turning off controls will not reduce this risk. Internal capacitors can remain charged for 5 minutes after disconnecting all sources of power.</p>
 	<p>CAUTION! Do not disassemble this inverter yourself. It contains no user-serviceable parts. Attempt to service this inverter yourself may cause a risk of electrical shock or fire and will void the warranty from the manufacturer.</p>
 	<p>CAUTION! To avoid a risk of fire and electric shock, make sure that existing wiring is in good condition and that the wire is not undersized. Do not operate the Inverter with damaged or substandard wiring.</p>
	<p>CAUTION! Under high temperature environment, the cover of this inverter could be hot enough to cause skin burns if accidentally touched. Ensure that this inverter is away from normal traffic areas.</p>
 	<p>CAUTION! Use only recommended accessories from installer. Otherwise, not-qualified tools may cause a risk of fire, electric shock, or injury to persons.</p>
	<p>CAUTION! To reduce risk of fire hazard, do not cover or obstruct the cooling fan.</p>
	<p>CAUTION! Do not operate the Inverter if it has received a sharp blow, been dropped, or otherwise damaged in any way. If the Inverter is damaged, please call for an RMA (Return Material Authorization).</p>
	<p>CAUTION! AC breaker, DC switch and Battery circuit breaker are used as disconnect devices and these disconnect devices shall be easily accessible.</p>
	<p>WARNING! Risk of Voltage Backfeed. Before working on this circuit, isolate inverter/Uninterruptible Power System (UPS); then check for Hazardous Voltage between all terminals including the protective earth.</p>

3. Unpacking & Overview

3-1. Packing List

Before installation, please inspect the unit. Be sure that nothing inside the package is damaged. You should have received the following items inside of package:

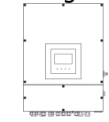

Inverter unit



RS-232 cable



Parallel cable



Share current wires



Manual



Fixing screws



WiFi antenna



Allen wrench

3-2. Product Overview

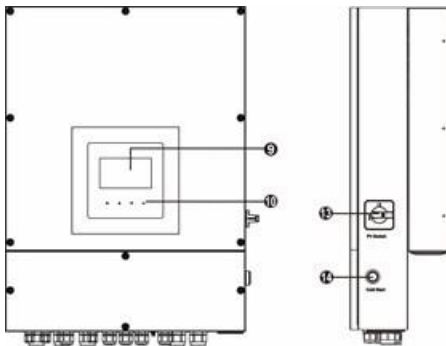

- 1) PV connectors
- 2) AC Grid connectors
- 3) Battery connectors
- 4) AC output connectors (Load connection)
- 5) Generator input
- 6) External sensor port
- 7) Dry contact & USB communication port
- 8) BMS & RS-232 communication port
- 9) LCD display panel (Please check section 13 for detailed LCD operation)
- 10) Operation buttons
- 11) Current sharing port
- 12) Parallel communication port
- 13) PV switch
- 14) Cold start button

4. Installation

4-1. Precaution

This hybrid inverter is designed for indoor or outdoor use (IP65), please make sure the installation site meets below conditions:

- Not in direct sunlight
- Not in areas where highly flammable materials are stored.
- Not in potential explosive areas.
- Not in the cool air directly.
- Not near the television Antenna or antenna cable.
- Not higher than altitude of about 2000 meters above sea level.
- Not in environment of precipitation or humidity (>95%).

Please AVOID direct sunlight, rain exposure, snow laying up during installation and operation.

4-2. Selecting Mounting Location

- Please select a vertical wall with load-bearing capacity for installation, appropriate for installation on concrete or other non-flammable surfaces.
- The ambient temperature should be between -25~60°C to ensure optimal operation.
- Be sure to keep other objects and surfaces as shown in the diagram to guarantee sufficient heat dissipation and have enough space for removing wires.
- For proper air ventilation to dissipate heat, allow a clearance of approx. 50cm to the side and approx. 50cm above and below the unit. And 100cm toward the front.



WARNING! FIRE HAZARD. ONLY SUITABLE FOR MOUNTING ON CONCRETE OR OTHER NON-COMBUSTIBLE SURFACE.

4.3. Mounting Unit



WARNING! Remember that this inverter is heavy! Please be careful when lifting it out from the package.

Installation to the wall should be implemented with the proper screws. After that, the device should be bolted on securely.

The inverter only can be used in a CLOSED ELECTRICAL OPERATING AREA. Only service

person can enter into this area.

1. Fix four screws as shown in the chart (width: 487mm, height: 350mm). The reference tightening torque is 35 N.m.

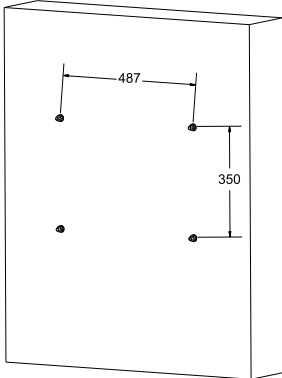

2. Raise the inverter and place it over the four screws.

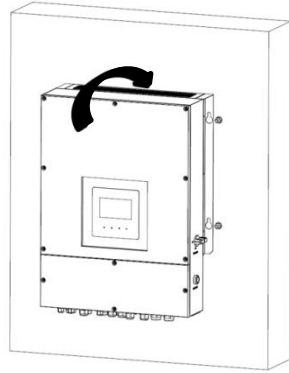

3. Check if the inverter is firmly secured.

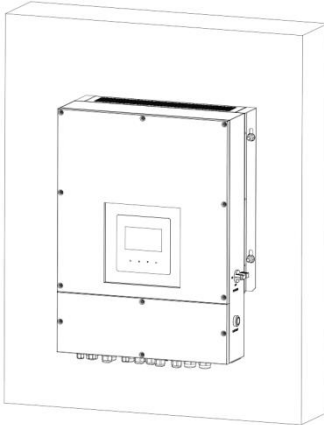

5. Grid (Utility) Connection

5-1. Preparation

NOTE 1: The overvoltage category of the AC input is III. It should be connected to the power distribution.

NOTE 2: Before connecting to grid, please install a separate AC breaker between inverter and grid. This will ensure the inverter can be securely disconnected during maintenance and fully protected from over current. The recommended of AC breaker is 40A/300V.

WARNING! It's very important for system safety and efficient operation to use appropriate cable for grid (utility) connection. To reduce risk of injury, please use the proper recommended cable size as below.

Suggested cable requirement for AC wire

Nominal Grid Voltage	120VAC per phase
Conductor cross-section (mm ²)	10-16
AWG no.	8-6

5-2. Connecting to the AC Utility

Please follow below steps to implement AC input connection:

1. Before making AC input connection, be sure to open DC protector or disconnector first.
2. Remove insulation sleeve 7mm for four conductors.
3. Insert AC input wires according to polarities indicated on terminal block and tighten the terminal screws. Be sure to connect PE protective conductor (⊕) first.

⊕ → **Ground (yellow-green)**

L1 → **LINE (black)**

L2 → **LINE (brown)**

N → **Neutral (blue)**

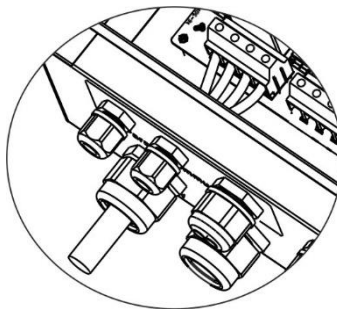

WARNING! Be sure that AC power source is disconnected before

attempting to hardwire it to the unit.

6. Generator Connection

6-1. Preparation

NOTE 1: The overvoltage category of the AC input is III. It should be connected to the power distribution.

NOTE 2: Before connecting to grid, please install a separate AC breaker between inverter and grid. This will ensure the inverter can be securely disconnected during maintenance and fully protected from over current. The recommended of AC breaker is 40A/300V.



WARNING! It's very important for system safety and efficient operation to use appropriate cable for generator connection. To reduce risk of injury, please use the proper recommended cable size as below.

Suggested cable requirement

Nominal Grid Voltage	120VAC per phase
Conductor cross-section (mm ²)	10-16
AWG no.	8-6

6-2. Connecting to the Generator Input

Please follow below steps to implement generator input connection:

1. Before making generator input connection, be sure to open DC protector or disconnecter first.
2. Remove insulation sleeve 7mm for four conductors.
3. Insert input wires according to polarities indicated on terminal block and tighten the terminal screws. Be sure to connect PE protective conductor (⊕) first.



→ **Ground (yellow-green)**

L1→ **LINE (black)**

L2→ **LINE (brown)**

N→ **Neutral (blue)**

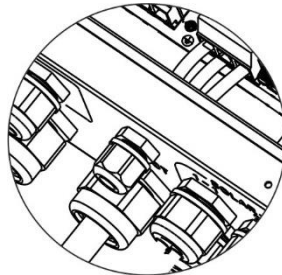



WARNING! Be sure that the generator power source is disconnected before attempting to hardwire it to the unit.

7. PV Module (DC) Connection

CAUTION: Before connecting to PV modules, please install **separately** a DC circuit breaker between inverter and PV modules.

NOTE1: Please use 1000VDC/20A circuit breaker.

NOTE2: The overvoltage category of the PV input is II.

Please follow below steps to implement PV module connection:



WARNING! Because this inverter is non-isolated, only two types of PV modules are acceptable: single crystalline and poly crystalline with class A-rated. To avoid any malfunction, do not connect any PV modules with the possibility of leakage current to the inverter. For example, grounded PV modules will cause leakage current to the inverter.



CAUTION: It's requested to have PV junction box with surge protection. Otherwise, it will cause inverter damage when lightning occurs on the PV modules.

Step 1: Check the input voltage of PV array modules. The acceptable input voltage of the inverter is 120VDC - 600VDC. This system is applied with two strings of PV array. Please make sure that the maximum current load of each PV input connector is 15A.

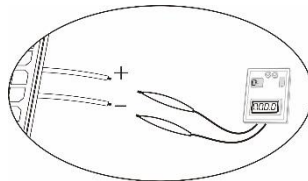

CAUTION: Exceeding the maximum input voltage can destroy the unit!! Check the system before wire connection.

Step 2: Disconnect the circuit breaker and switch off the DC switch.

Step 3: Remove insulation sleeve 7 mm for positive and negative conductors.

Step 4: Check correct polarity of connection cable from PV modules and PV input connectors. Then, connect positive pole (+) of connection cable to positive pole (+) of PV input connector. Connect negative pole (-) of connection cable to negative pole (-) of PV input connector.

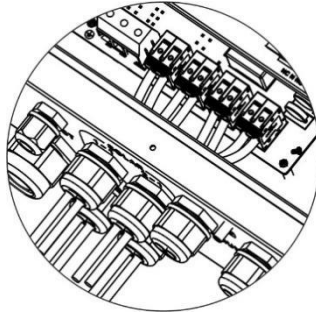

WARNING! It's very important for system safety and efficient operation to use appropriate cable for PV module connection. To reduce risk of injury, please use the proper recommended cable size as below.

Conductor cross-section (mm ²)	AWG no.
4	12



CAUTION: Never directly touch terminals of the inverter. It will cause lethal electric shock.

CAUTION: Do NOT touch the inverter to avoid electric shock. When PV modules are exposed to sunlight, it may generate DC voltage to the inverter.

Recommended Panel Configuration

Specifications	Solar panel			
Nominal Max. Power (Pmax) (W)	430	455	520	535
Opt. Operating Voltage (Vmp) (V)	40.3	41.3	41.6	41.9
Opt. Operating Current (Imp) (A)	10.68	11.02	12.5	12.77
Open Circuit Voltage (Voc) (V)	48.3	49.3	49.14	49.44
Short Circuit Current (Isc) (A)	11.37	11.66	13.23	13.5
For 7.5KW input recommendation				
Numbers in series of MPPT1	12	11	11	10
Numbers of strings in MPPT1	1	1	1	1
Max. input voltage of MPPT1 (V)	579.6	542.3	540.54	494.4
Input power of MPPT1(W)	5160	5005	5720	5350
Numbers in series of MPPT2	6	6	4	5
Numbers of strings in MPPT2	1	1	1	1
Max. input voltage of MPPT2 (V)	289.8	295.8	196.56	247.2
Input power of MPPT2(W)	2580	2730	2080	2675
Total input power (W)	7740	7735	7800	8025
Minimum input recommendation				
Numbers in series of MPPT1	5	5	5	5
Numbers of strings in MPP1	1	1	1	1
Max. input voltage of MPPT1 (V)	241.5	246.5	245.7	247.2
Input power of MPP1 (W)	2150	2275	2600	2675
Numbers in series of MPPT1	5	5	5	5
Numbers of strings in MPP1	1	1	1	1
Max. input voltage of MPPT1 (V)	241.5	246.5	245.7	247.2
Input power of MPP1 (W)	2150	2275	2600	2675
Total input power (W)	4300	4550	5200	5350

8. Battery Connection



CAUTION: Before connecting to batteries, please install separately a DC circuit breaker between inverter and batteries.

NOTE1: Please only use sealed lead acid battery, vented and Gel battery. Please check maximum charging voltage and current when first using this inverter. If using Lithium iron or Nicd battery, please consult with installer for the details.

NOTE2: Please use 60VDC/200A circuit breaker.

NOTE3: The overvoltage category of the battery input is II.

Please follow below steps to implement battery connection:

Step 1: Check the nominal voltage of batteries. The nominal input voltage for inverter is 48VDC.

Step 2: Use two battery cables. Remove insulation sleeve 18 mm and insert conductor into cable terminal. Refer to right chart.

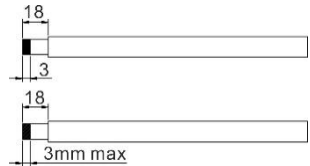

The cable size of each inverter is shown as below:

Recommended battery cable and terminal size for each inverter:

Wire Size	Cable mm ²	Terminal Dimensions			Torque value
		E (mm)	W (mm)	L (mm)	
		1/0 AWG	53.5	8.4	

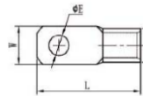

WARNING! Be sure the length of all battery cables are the same. Otherwise, there will be a voltage difference between inverter and battery and cause parallel inverters to not work.

Step 3: Insert battery wires according to polarities indicated on the terminal block and tighten the terminal screws. Make sure polarity at both the battery and the inverter/charge is correctly connected.

RED cable to the positive terminal (+);
BLACK cable to the negative terminal (-).

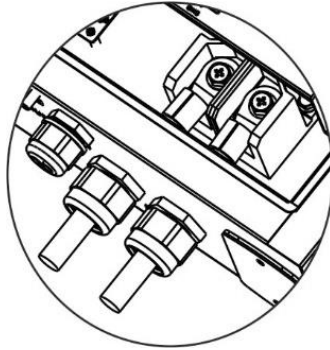

WARNING! Wrong connections will damage the unit permanently.

Step 4: Make sure the wires are securely connected. The reference tightening torque is 5 N.m.

9. Load (AC Output) Connection

9-1. Preparation



CAUTION: To prevent further supply to the load via the inverter during any mode of operation, an additional disconnection device should be placed on in the building wiring installation.



WARNING! It's very important for system safety and efficient operation to use the appropriate cable for AC connection. To reduce the risk of injury, please use the recommended cable size.

Nominal Grid Voltage	120/208/240 VAC per phase
Conductor cross-section (mm ²)	5.5-10
AWG no.	10-8

9-2. Connecting to the AC output

Step 1: Before making output connection, be sure to open DC protector or disconnector first.

Step 2: Remove insulation sleeve 7mm for four conductors.

Step 3: Insert AC input wires according to polarities indicated on terminal block and tighten the terminal screws. Be sure to connect PE protective conductor (⊕) first.

- ⊕ → **Ground (yellow-green)**
- L1** → **LINE (black)**
- L2** → **LINE (brown)**
- N** → **Neutral (blue)**

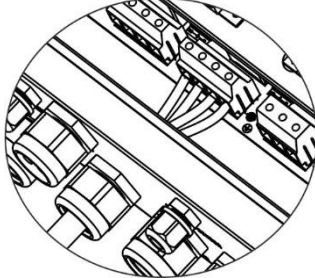

The reference tightening torque is 1.0-1.5 N.m.

Step 4: Make sure the wires are securely connected.



CAUTION: Do NOT connect the utility to “AC Output Connector (Load connector)”.

CAUTION: Be sure to connect L terminal of load to L terminal of AC Output Connector (Load connector)” and N terminal of load to N terminal of AC Output Connector (Load connector)”. The G terminal of AC Output Connector is connected to grounding of the load. Do NOT mis-connect.

CAUTION: Appliances such as air conditioners require at least 2~3 minutes to restart because it’s required to have enough time to balance refrigerant gas inside of circuits. If a power shortage occurs and recovers in a short time, it will cause damage to your connected appliances. To prevent this kind of damage, please check the manufacturer of the air conditioner if it’s equipped with a time delay function before installation. Otherwise, this inverter/charger will trigger an overload fault and cut off output to protect your appliance but sometimes it still causes internal damage to the air conditioner.

10. Communication

The inverter is equipped with several communication ports to communicate with a PC with corresponding software. Follow below procedure to connect communication wiring and install the software.

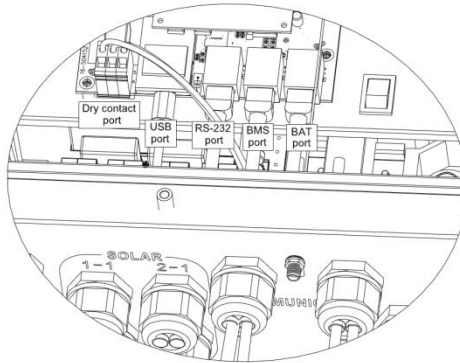

Please install monitoring software in your computer. Detailed information is listed in the next chapter. After software is installed, you may initial the monitoring software and extract data through communication port.

10-1. Wi-Fi Connection

This unit is equipped with a Wi-Fi transmitter. Wi-Fi transmitter can enable wireless communication between inverter and monitoring platform. Users can access and control the monitored inverter with downloaded APP. Please check the installer for the APP details.

10-2. Pin Assignment for RS-232 Communication Port

	Definition
PIN 1	RS232TX
PIN 2	RS232RX
PIN 3	NC
PIN 4	8~12V
PIN 5	NC
PIN 6	NC
PIN 7	NC
PIN 8	GND

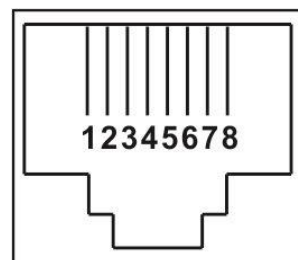

10-3. Pin Assignment for BMS Communication Port

	Definition
PIN 1	RS232TX
PIN 2	RS232RX
PIN 3	RS485B
PIN 4	NC
PIN 5	RS485A
PIN 6	CANH
PIN 7	CANL
PIN 8	GND

10-4. Pin Assignment for BAT Communication Port

	Definition
PIN 1	NC
PIN 2	NC
PIN 3	RS485B
PIN 4	NC
PIN 5	RS485A
PIN 6	NC
PIN 7	NC
PIN 8	NC

10-5. Dry Contact Signal

There is one dry contact available on the bottom panel. It could be used to remote control for external generator. There are two different logic commands available. You may select either one by running the command \wedge S004DRY0 or \wedge S004DRY1.

Electric Parameter

Parameter	Symbol	Max.	Unit
Relay DC voltage	Vdc	30	V
Relay DC current	Idc	1	A

Note: The application of the dry contact should not exceed the electric parameter shown as above. Otherwise, the internal relay will be damaged.

Logic 1: Command ^S004DRY0

This is the default setting.

Function Description

Unit Status	Condition	Dry contact port: 	
		NO&C	NC&C
Power Off	Unit is off and no output is powered.	Open	Close
Power On	Battery voltage is lower than setting battery cut-off discharging voltage when grid is available.	Close	Open
	Battery voltage is lower than setting battery cut-off discharging voltage when grid is unavailable.	Close	Open
	One of the following condition is met. 1. Battery voltage is higher than below 2 setting values: <ul style="list-style-type: none"> ● Battery re-discharging voltage when grid is available. ● Battery re-discharging voltage when grid unavailable. 2. The inverter is in fault mode. 3. Communication between DSP and communication board is lost.	Open	Close

Logic 2: Command ^S004DRY1

Function Description

Unit Status	Condition	Dry contact port: 	
		NO&C	NC&C
Power Off	Unit is off and no output is powered.	Open	Close
Power On	Battery voltage is lower than GSV* when grid is unavailable.	Close	Open
	One of the following condition is met. 1. Battery voltage is higher than Battery re-discharging voltage when grid unavailable 2. The inverter is in fault mode. 3. Communication between DSP and communication board is lost. 4. Grid is ok	Open	Close

* GSV= battery cut-off discharging voltage when grid is unavailable+1.5V.

You can set the related parameters through LCD operation or software. Refer to LCD

setting 9, 10, 11 and 12 in LCD setting section. If using software, refer to below chart.

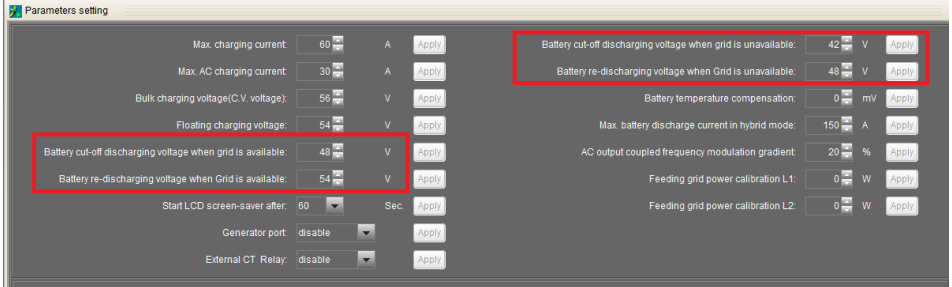

11. Commissioning

Step 1: Check the following requirements before commissioning:

- Ensure the inverter is firmly secured
- Check if the open circuit DC voltage of PV module meets requirement (Refer to Section 7)
- Check if the open circuit utility voltage of the utility is at approximately same to the nominal expected value from local utility company.
- Check if connection of AC cable to grid (utility) is correct if the utility is required.
- Full connection to PV modules.
- AC circuit breaker (only applied when the utility is required), batter circuit breaker, and DC circuit breaker are installed correctly.

Step 2: Switch on the battery circuit breaker and then switch on PV DC breaker. After that, if there is utility connection, please switch on the AC circuit breaker. At this moment, the inverter is turned on already. However, there is no output generation for loads. Then:

- If LCD lights up to display the current inverter status, commissioning has been successfully. After pressing "ENTER" or "Cold Start" button for 3 seconds when the utility is detected, this inverter will start to supply power to the loads.
- If a warning/fault indicator appears in LCD, an error has occurred to this inverter. Please inform your installer.

12. Initial Setup

Before inverter operation, it's required to set up "Operation Mode" via software. Please strictly follow below steps to set up. For more details, please check software manual.

Step 1: After turning on the inverter and installing the software, please click "Open Monitor" to enter main screen of this software.

Step 2: Log in into software first by entering default password "administrator".

Step 3: Select Device Control >> MyPower Management. It is to set up inverter operation mode and personalized interface. Refer to diagram below.

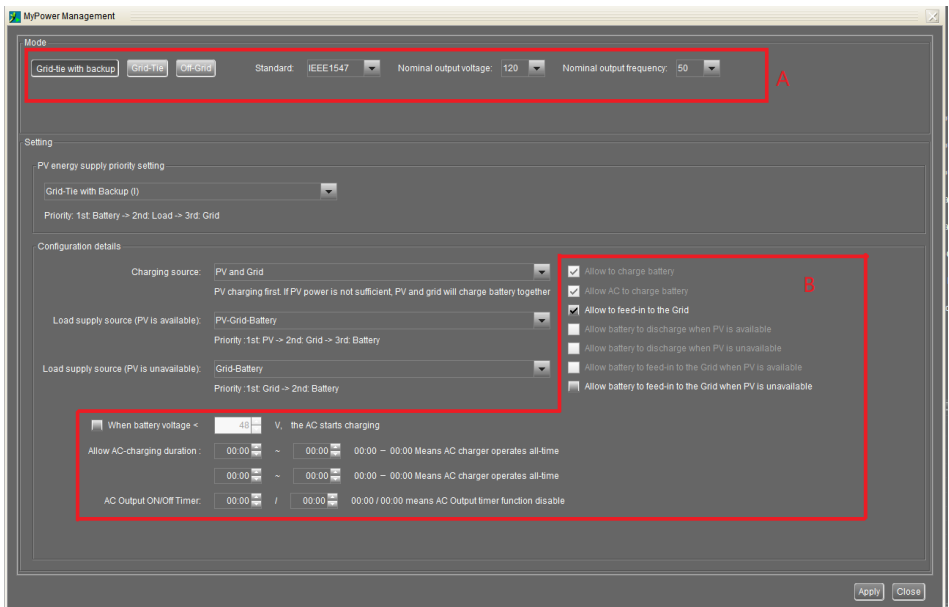
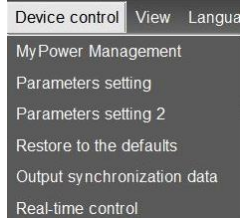

SECTION A:

Mode (Refer to LCD setting 13)

There are three operation modes: Grid-tie with backup, Grid-Tie and Off-Grid.

- Grid-tie with backup: PV power can feed-in back to grid, provide power to the load and charge battery. There are four options available in this mode: Grid-

tie with backup I, II, III and IV. In this mode, users can configure PV power supply priority, charging source priority and load supply source priority. However, when Grid-tie with backup IV option is selected in PV energy supply priority, the inverter is only operated between two working logics based on defined peak time and off-peak time of electricity. Only peak time and off-peak time of electricity are able to set up for optimized electricity usage.

- Grid-Tie: PV power only can feed-in back to grid.
- Off-Grid: PV power only provides power to the load and charge battery. No feed-in back to grid is allowed.

Standard (It can only be modified by software)

It will list local grid standard. It's requested to have factory password to make any modifications. Please check local dealer only when this standard change is requested.

CAUTION: Wrong setting could cause the unit damage or not working.

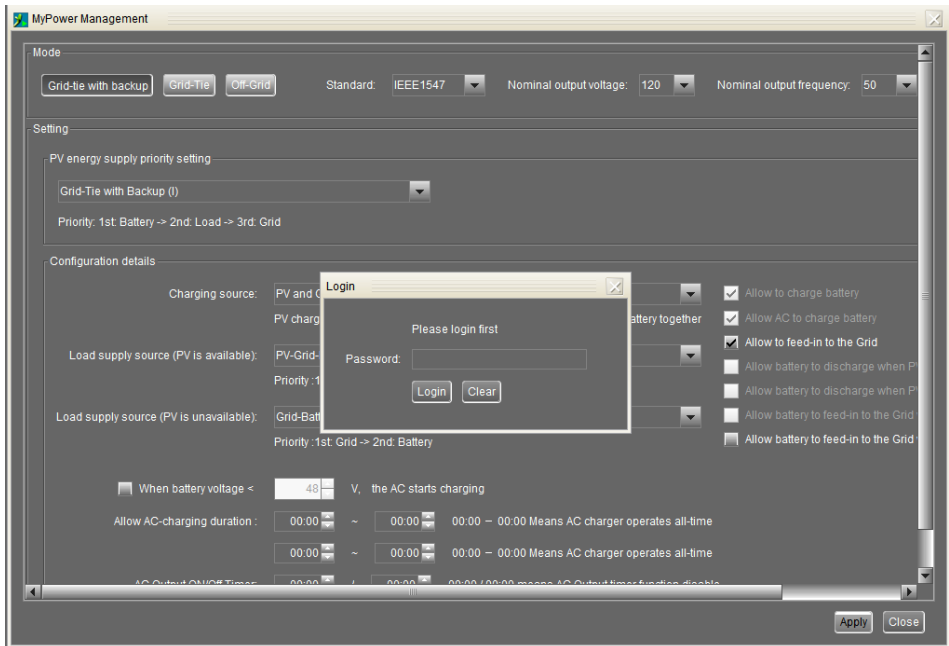

Nominal Output Voltage (Refer to LCD setting 01)

The factory default voltage is 120V. You can select 110V or 120V as required.

Nominal Output Frequency (Refer to LCD setting 02)

The factory default frequency is 60hz. You can select 50Hz or 60Hz as required.

SECTION B: Setting

This section contents may be different based on different selected types of operations.

Allow AC charging duration (Refer to LCD setting 21-24)

It's a period time to allow AC (grid) to charge battery. When the duration is set up as 0:00-00:00, it means no time limitation for AC to charge battery.

AC output ON/Off Timer (Refer to LCD setting 25, 26)

Set up on/off time for AC output of inverter. If setting it as 00:00/00:00, this function is disabled.

Allow to charge battery (Refer to LCD setting 15)

This option is automatically determined by setting in "Charging source". It's not allowed to modify here. When "NONE" is selected in charging source section, this option becomes unchecked as grey text.

Allow AC to charge battery (Refer to LCD setting 15)

This option is automatically determined by setting in "Charging source". It's not allowed to modify here. When "Grid and PV" or "Grid or PV" is selected in charging source section, this option is default selected. Under Grid-tie mode, this option is invalid.

Allow to feed-in to the Grid (Refer to LCD setting 16)

This option is only valid under Grid-tie and Grid-tie with backup modes. Users can decide if this inverter can feed-in to the grid.

Allow battery to discharge when PV is available

This option is automatically determined by setting in "Load supply source (PV is available)". When "Battery" is higher priority than "Grid" in Load supply source (PV is available), this option is default selected. Under Grid-tie, this option is invalid.

Allow battery to discharge when PV is unavailable

This option is automatically determined by setting in "Load supply source (PV is unavailable)". When "Battery" is higher priority than "Grid" in Load supply source (PV is unavailable), this option is default selected. Under Grid-tie mode, this option is invalid.

Allow battery to feed-in to the Grid when PV is available (Refer to LCD setting 17)

This option is only valid in Grid-tie with backup II or Grid-tie with backup III modes.

Allow battery to feed-in to the Grid when PV is unavailable (Refer to LCD setting 16)

This option is only valid in all options of Grid-tie with backup mode.

PV energy support priority setting (Refer to LCD setting 14)

It will affect the selection of "Battery charging source (LCD setting 15)", "Load supply source (LCD setting 19 and 20)".

Grid-tie with backup

- Grid-tie with backup (I) :

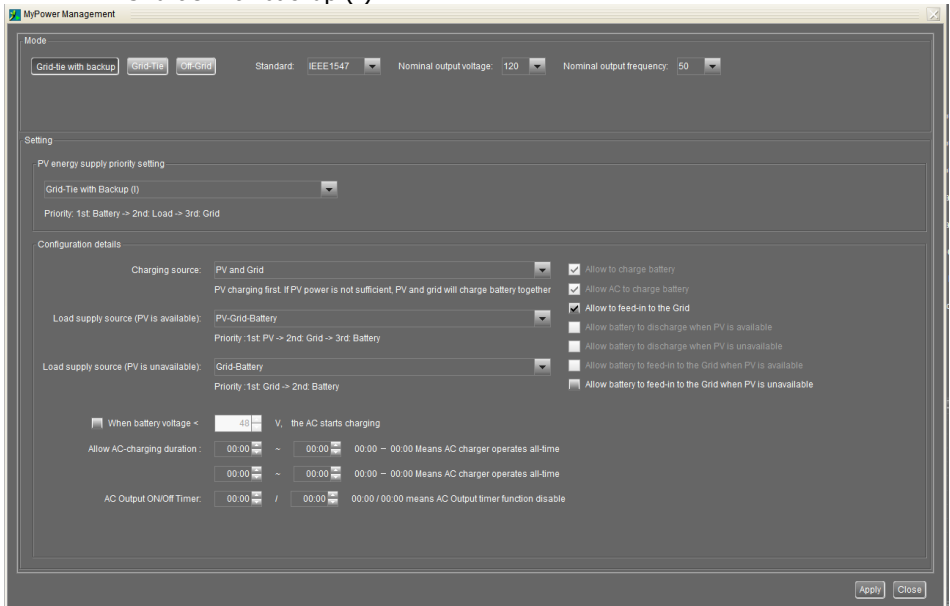

PV energy supply priority setting: 1st Battery, 2nd Load and 3rd Grid.

PV power will charge battery first, then provide power to the load. If there is any remaining power left, it will feed-in to the grid.

Battery charging source:

1. PV and Grid (Default)

It's allowed to charge battery from PV power first. If it's not sufficient, grid will charge battery.

2. PV only

It is only allow PV power to charge battery.

3. None

It is not allowed to charge battery no matter it's from PV power or grid.

Load supply source: (also refer to LCD setting 19 and 20)

When PV power is available: 1st PV, 2nd Grid, 3rd Battery

If battery is not fully charged, PV power will charge battery first. And remaining PV

power will provide power to the load. If it's not sufficient, grid will provide power to the load. If grid is not available at the same time, battery power will back up.

When PV power is not available:

1. 1st Grid, 2nd Battery (Default)

Grid will provide power to the load at first. If grid is not available, battery power will provide power backup.

2. 1st Battery, 2nd Grid

Battery power will provide power to the load at first. If battery power is running out, grid will back up the load.

NOTE: This option will become ineffective during AC charging time and the priority will automatically become 1st Grid and 2nd Battery order. Otherwise, it will cause battery damage.

● Grid-tie with backup (II) :

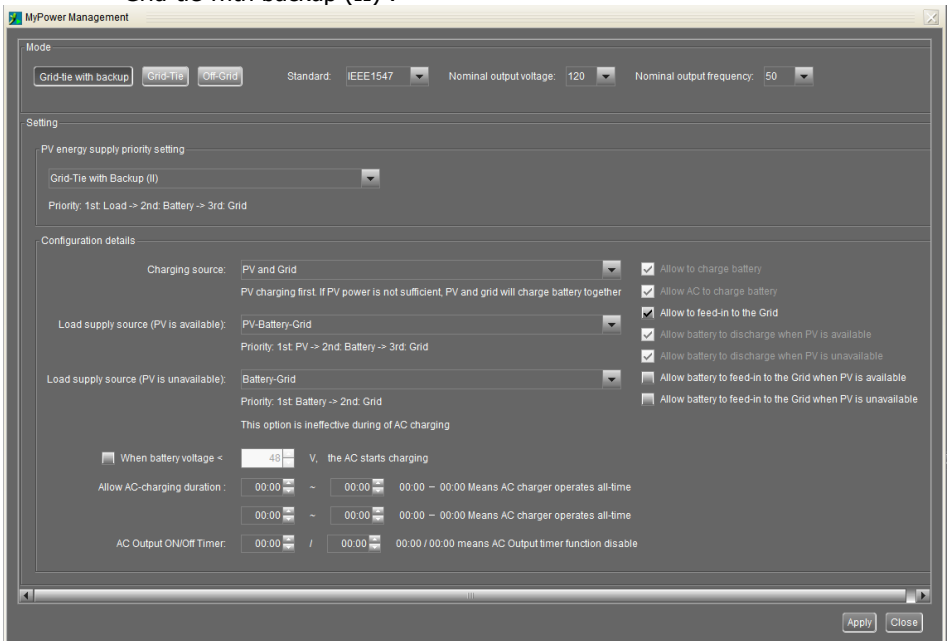

PV energy supply priority setting: 1st Load, 2nd Battery and 3rd Grid.

PV power will provide power to the load first. Then, it will charge battery. If there is any remaining power left, it will feed-in to the grid.

Battery charging source:

1. PV and Grid

It's allowed to charge battery from PV power first. If it's not sufficient, grid will charge battery.

2. PV only

It is only allow PV power to charge battery.

3. None

It is not allowed to charge battery no matter it's PV power or grid.

Load supply source:

When PV power is available:

1. 1st PV, 2nd Battery, 3rd Grid

PV power will provide power to the load first. If it's not sufficient, battery power will provide power to the load. When battery power is running out or not available, grid will back up the load.

NOTE: This option will become ineffective during AC charging time and the priority will automatically become 1st PV, 2nd Grid and 3rd Battery in order. Otherwise, it will cause battery damage.

2. 1st PV, 2nd Grid, 3rd Battery

PV power will provide power to the load first. If it's not sufficient, grid will provide power to the load. If grid is not available at the same time, battery power will back up.

When PV power is not available:

1. 1st Grid, 2nd Battery: Grid will provide power to the load at first. If grid is not available, battery power will provide power backup.

2. 1st Battery, 2nd Grid: Battery power will provide power to the load at first. If battery power is running out, grid will back up the load

NOTE: This option will become ineffective during AC charging time and the priority will automatically become 1st Grid and 2nd Battery order. Otherwise, it will cause battery damage.

● Grid-tie with backup (III):

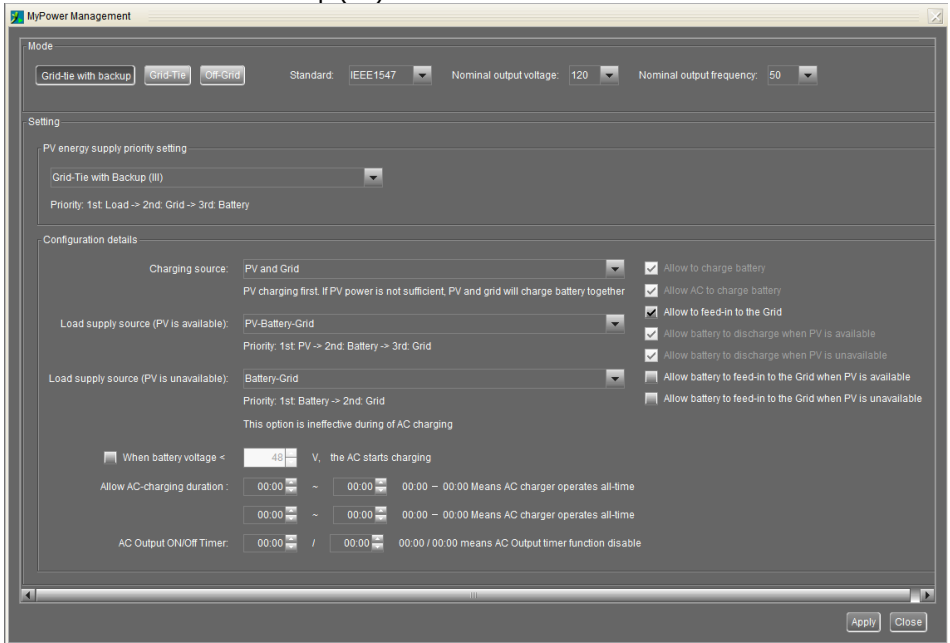

PV energy supply priority setting: 1st Load, 2nd Grid and 3rd Battery

PV power will provide power to the load first. If there is more PV power available, it will feed-in to the grid. If feed-in power reaches max. feed-in power setting, the remaining power will charge battery.

NOTE: The max. feed-in grid power setting is available in parameter setting. Please refer to software manual.

Battery charging source:

1. PV and Grid: It's allowed to charge battery from PV power first. If it's not sufficient, grid will charge battery.
2. PV only: It is only allow PV power to charge battery.
3. None: It is not allowed to charge battery no matter it's PV power or grid.

Load supply source:

When PV power is available:

1. 1st PV, 2nd Battery, 3rd Grid

PV power will provide power to the load first. If it's not sufficient, battery power will provide power to the load. When battery power is running out or not available, grid will back up the load.

NOTE: This option will become ineffective during AC charging time and the priority will automatically become 1st PV, 2nd Grid and 3rd Battery in order. Otherwise, it will cause battery damage.

2. 1st PV, 2nd Grid, 3rd Battery

PV power will provide power to the load first. If it's not sufficient, grid will provide power to the load. If grid is not available at the same time, battery power will back up.

When PV power is not available:

1. 1st Grid, 2nd Battery: Grid will provide power to the load at first. If grid is not available, battery power will provide power backup.
2. 1st Battery, 2nd Grid: Battery power will provide power to the load at first. If battery power is running out, grid will back up the load.

NOTE: This option will become ineffective during AC charging time and the priority will automatically become 1st Grid and 2nd Battery order. Otherwise, it will cause battery damage.

- Grid-tie with backup (IV): Users are only allowed to set up peak time and off-peak electricity demand.

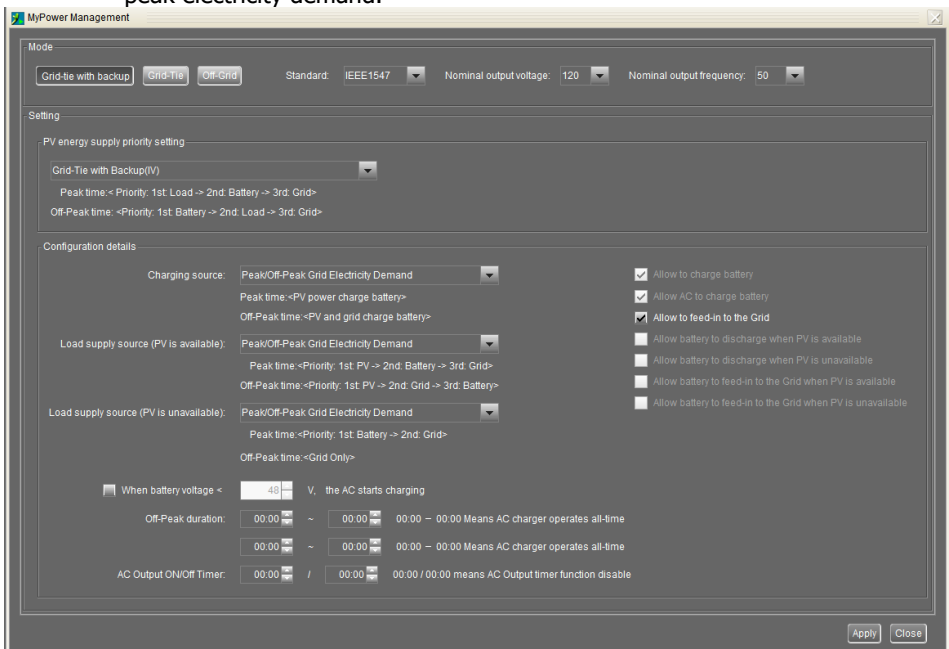

Working logic under peak time:

PV energy supply priority: 1st Load, 2nd Battery and 3rd Grid

PV power will provide power to the load first. If PV power is sufficient, it will charge battery next. If there is remaining PV power left, it will feed-in to the grid. Feed-in to the grid is default disabled.

Battery charging source: PV only

Only after PV power fully supports the load, the remaining PV power is allowed to

charge battery during peak time.

Load supply source: 1st PV, 2nd Battery, 3rd Grid

PV power will provide power to the load first. If PV power is not sufficient, battery power will back up the load. If battery power is not available, grid will provide the load. When PV power is not available, battery power will supply the load first. If battery power is running out, grid will back up the load.

Working logic under off-peak time:

PV energy supply priority: 1st Battery, 2nd Load and 3rd Grid

PV power will charge battery first. If PV power is sufficient, it will provide power to the loads. The remaining PV power will feed to the grid.

NOTE: The max. feed-in grid power setting is available in parameter setting. Please refer to software manual.

Battery charging source: PV and grid charge battery

PV power will charge battery first during off-peak time. If it's not sufficient, grid will charge battery.

Load supply source: 1st PV, 2nd Grid, 3rd Battery

When battery is fully charged, remaining PV power will provide power to the load first. If PV power is not sufficient, grid will back up the load. If grid power is not available, battery power will provide power to the load.

Grid-Tie

Under this operation mode, PV power only feeds-in to the grid. No priority setting is available.

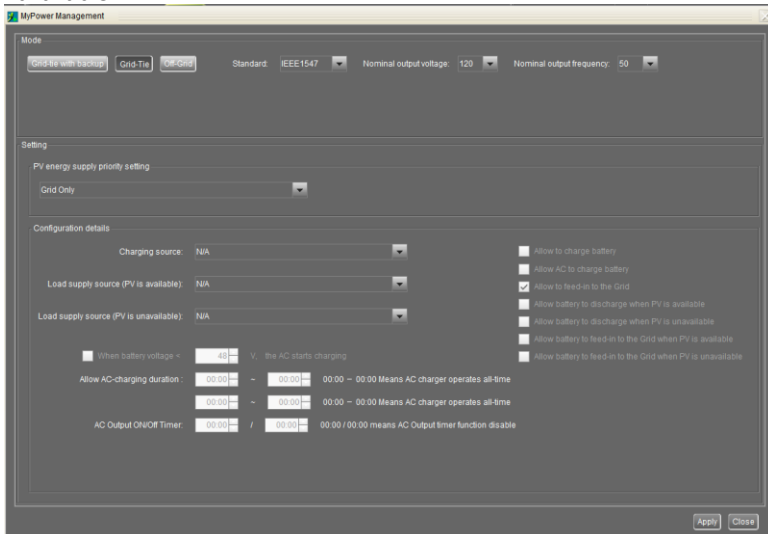

Off-Grid

- Off-Grid (I): Default setting for off-grid mode.

The screenshot shows the 'MyPower Management' software interface. At the top, there are three mode selection buttons: 'Grid-Tie with backup', 'Grid-Tie', and 'Off-Grid'. The 'Off-Grid' button is selected. Below the mode selection, there are dropdown menus for 'Standard' (set to 'VDE0126'), 'Nominal output voltage' (set to '120'), and 'Nominal output frequency' (set to '50').

The 'Setting' section is titled 'PV energy supply priority setting'. It shows a dropdown menu set to 'Off-Grid (I)'. Below this, it states 'Priority: 1st Load -> 2nd: Battery' and 'Grid relay is connected in inverter mode'.

The 'Configuration details' section contains several settings:

- 'Charging source: PV or Grid' (dropdown menu)
- 'Load supply source (PV is available): PV-Battery-Grid' (dropdown menu)
- 'Load supply source (PV is unavailable): Battery-Grid' (dropdown menu)
- 'Priority: 1st: PV -> 2nd: Battery -> 3rd: Grid' (text)
- 'This option is ineffective during AC charging' (text)
- 'When battery voltage < 48 V, the AC starts charging' (text with a numeric input field set to 48)
- 'Allow AC-charging duration: 00:00 ~ 00:00 00:00 - 00:00 Means AC charger operates all-time' (text with two time input fields)
- 'AC Output ON/Off Timer: 00:00 / 00:00 00:00 / 00:00 means AC Output timer function disable' (text with two time input fields)

On the right side of the 'Configuration details' section, there are several checkboxes:

- Allow to charge battery
- Allow AC to charge battery
- Allow to feed-in to the Grid
- Allow battery to discharge when PV is available
- Allow battery to feed-in to the Grid when PV is available
- Allow battery to feed-in to the Grid when PV is unavailable

At the bottom right of the window, there are 'Apply' and 'Close' buttons.

PV energy supply priority setting: 1st Load, 2nd Battery

PV power will provide power to the load first and then charge battery. Feed-in to the grid is not allowed under this mode. At the same time, the grid relay is connected in Inverter mode. That means the transfer time from inverter mode to battery mode will be less than 15ms. Besides, it will avoid overload fault because grid can supply load when connected load is over rated output capacity of the inverter.

Battery charging source:

1. PV or Grid: If there is remaining PV power after supporting the loads, it will charge battery first. Only until PV power is not available, grid will charge battery. (Default)
2. PV only: It is only allow PV power to charge battery.
3. None: It is not allowed to charge battery no matter it's PV power or grid.

Load supply source:

When PV power is available:

1. 1st PV, 2nd Battery, 3rd Grid (Default)

PV power will provide power to the load first. If it's not sufficient, battery power will provide power to the load. When battery power is running out or not available, grid will back up the load.

2. 1st PV, 2nd Grid, 3rd Battery

PV power will provide power to the load first. If it's not sufficient, grid will provide power to the load. If grid is not available at the same time, battery power will back

up.

When PV power is not available:

1. 1st Grid, 2nd Battery

Grid will provide power to the load at first. If grid is not available, battery power will provide power backup.

2. 1st Battery, 2nd Grid (Default)

Battery power will provide power to the load at first. If battery power is running out, grid will back up the load.

NOTE: This option will become ineffective during AC charging time and the priority will automatically become 1st Grid and 2nd Battery order. Otherwise, it will cause battery damage.

● Off-Grid (II)

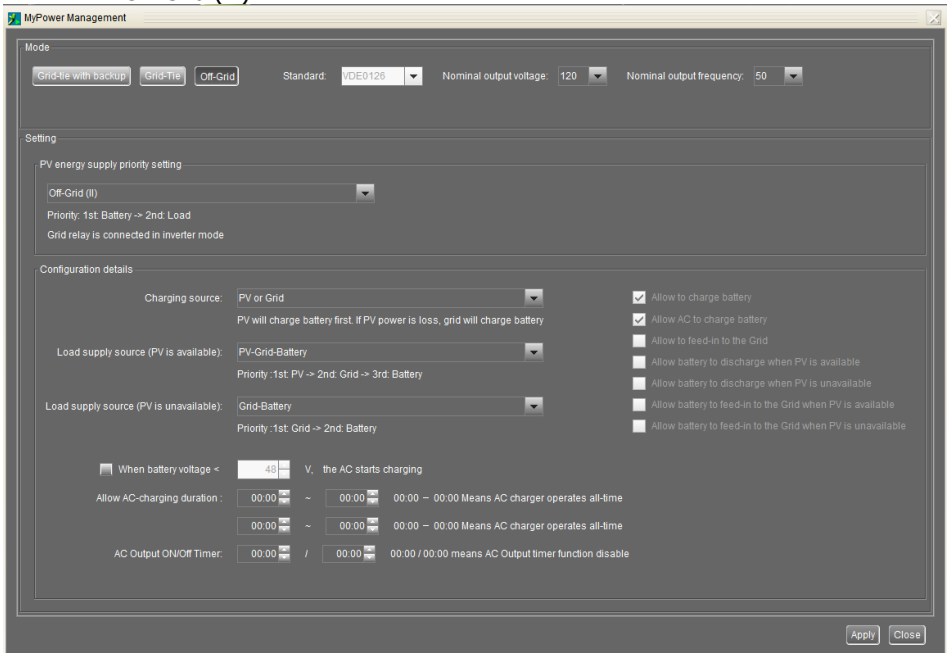

PV energy supply priority setting: 1st Battery, 2nd Load

PV power will charge battery first. After battery is fully charged, if there is remaining PV power left, it will provide power to the load. Feed-in to the grid is not allowed under this mode. At the same time, the grid relay is connected in Inverter mode. That means the transfer time from inverter mode to battery mode will be less than 15ms. Besides, it will avoid overload fault because grid can supply load when connected load is over rated output capacity of the inverter.

Battery charging source:

1. PV or Grid: If there is remaining PV power after supporting the loads, it will charge battery first. Only until PV power is not available, grid will charge battery.
2. PV only: It is only allow PV power to charge battery.
3. None: It is not allowed to charge battery no matter it's PV power or grid.

NOTE: It's allowed to set up AC charging duration.

Load supply source:

When PV power is available: 1st PV, 2nd Grid, 3rd Battery

PV power will provide power to the load first. If it's not sufficient, grid will provide power to the load. If grid is not available at the same time, battery power will back up.

When PV power is not available:

1. 1st Grid, 2nd Battery: Grid will provide power to the load at first. If grid is not available, battery power will provide power backup.
2. 1st Battery, 2nd Grid: Battery power will provide power to the load at first. If battery power is running out, grid will back up the load.

NOTE: This option will become ineffective during AC charging time and the priority will automatically become 1st Grid and 2nd Battery order. Otherwise, it will cause battery damage.

● Off-Grid (III)

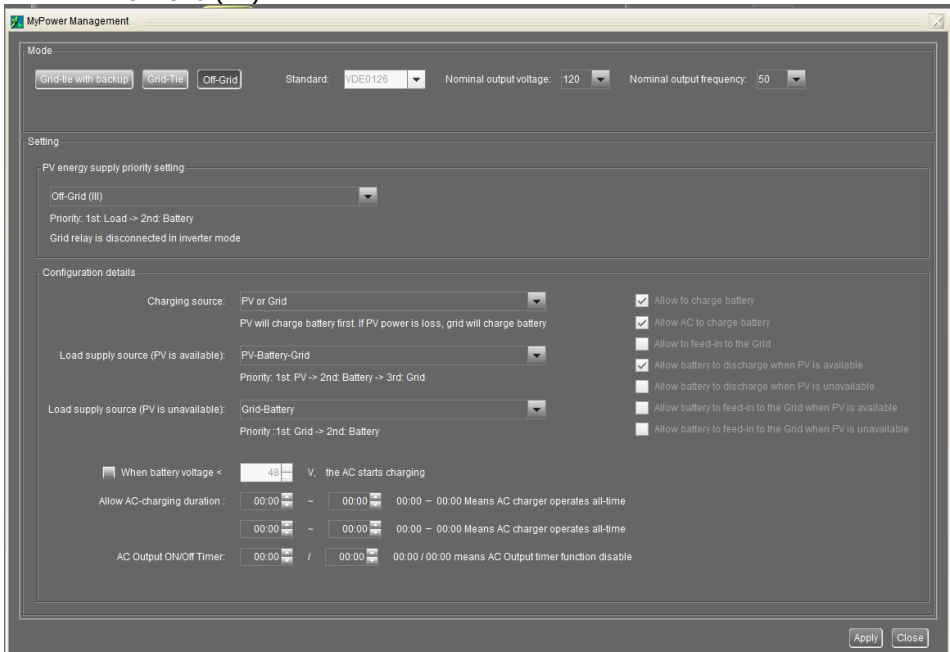

PV energy supply priority setting: 1st Load, 2nd Battery

PV power will provide power to load first and then charge battery. Feed-in to the grid is not allowed under this mode. The grid relay is NOT connected in Inverter mode. That means the transfer time from inverter mode to battery mode will be about 15ms. If connected load is over rated output capacity of the inverter and grid is available, this inverter will allow grid to provide power to the loads and PV power to charge battery. Otherwise, this inverter will activate fault protection.

Battery charging source:

1. PV or Grid: If there is remaining PV power after supporting the loads, it will charge battery first. Only until PV power is not available, grid will charge battery.
2. PV only: It is only allow PV power to charge battery.
3. None: It is not allowed to charge battery no matter it's PV power or grid.

NOTE: It's allowed to set up AC charging duration.

Load supply source:

When PV power is available: 1st PV, 2nd Battery, 3rd Grid

PV power will provide power to the load first. If it's not sufficient, battery power will back up the load. Only after battery power is running, Grid will back up the load.

When PV power is not available:

1. 1st Grid, 2nd Battery: Grid will provide power to the load at first. If grid is not available, battery power will provide power backup.
2. 1st Battery, 2nd Grid: Battery power will provide power to the load at first. If battery power is running out, grid will back up the load.

NOTE: This option will become ineffective during AC charging time and the priority will automatically become 1st Grid and 2nd Battery order. Otherwise, it will cause battery damage.

13. Operation

13-1. Interface



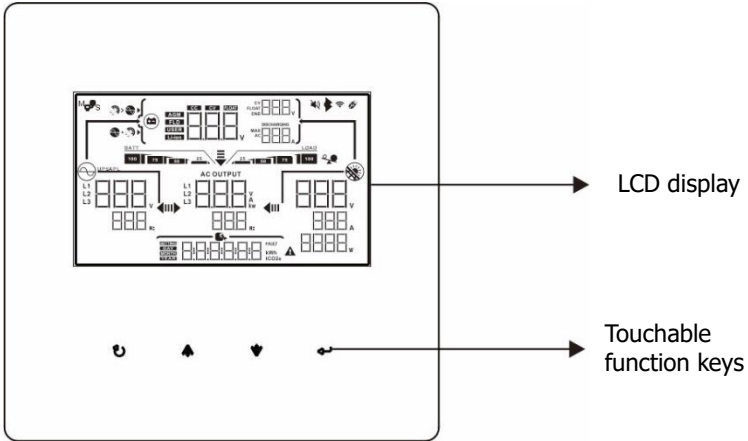





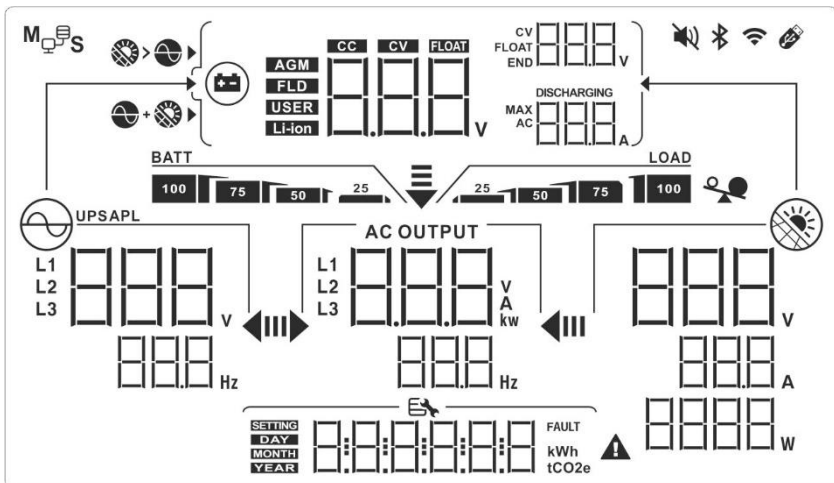

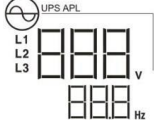
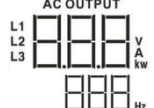
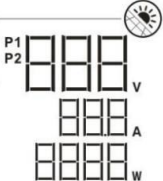
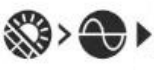

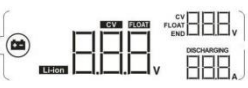
The operation LCD panel, shown in the chart below, includes four touchable function keys and a LCD display to indicate the operating status and input/output power information.





NOTICE: To accurately monitor and calculate the energy generation, please calibrate the timer of this unit via software every one month. For the detailed calibration, please check the user manual of bundled software.



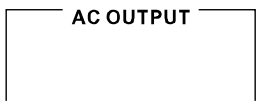

13-2. LCD Information Define



Display	Function
	<p>Indicates AC input voltage and frequency. V: voltage, Hz: frequency, L1/L2/L3: Line phase</p>
	<p>Indicates AC output power, voltage, frequency, or current. kw: active power, V: voltage, Hz: frequency, A: current L1/L2/L3: AC output phase</p>
	<p>Indicates PV input voltage, power or current. V: voltage, W: power, P1: PV input 1, P2: PV input 2 A: current</p>
	<p>Allow AC and PV charging</p>
	<p>Only PV charging is allowed</p>
	<p>Indicates battery voltage, battery current, charging status or battery parameters V: voltage, A: current, Li-ion: Lithium-ion battery type</p>
	<p>Indicates battery level in battery mode.</p>
	<p>Indicates the warning and fault codes.</p>
	<p>Indicates date and time or the date and time users set for querying energy generation.</p>
	<p>Indicates solar panels. Icon flashing indicates PV input voltage is out of range.</p>
	<p>Indicates utility. Icon flashing indicates utility voltage or frequency is out of range.</p>
	<p>Indicates battery condition. And the lattice of the icon indicates battery capacity.</p>
	<p>Icon  flashing indicates battery is not allowed to discharge.</p>
	<p>Icon  flashing indicates the battery voltage is too low.</p>

	Indicates AC output for loads is enabled and inverter is providing power to the connected loads.
	Indicates AC output for loads is enabled but there is no power provided from inverter. At this time, no battery and the utility are available. Only PV power exists but is not able to provide power to the connected loads.
	Indicates overload.
	Indicates parallel operation is working.

13-3. Touchable function keys

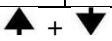
Function Key		Operation	Function
	Enter/ON	Quick touch.	Enter query menu. If it's in query menu, touch this button to confirm selection or entry.
		Touch and hold the button for approximately 3 seconds no matter the utility is detected or not.	This inverter is able to provide power to connected loads via AC output connector.
	ESC/OFF	Quick touch.	Return to previous menu.
		Touch and hold the button until the buzzer continuously sounds.	Turn off the AC output when no AC charging or feed-in operation. Otherwise, the SW OFF will show on LCD only until the AC input removed, then, AC output will be OFF.
	Up	Quick touch.	Select last selection or increase value.
	Down	Quick touch.	If it's in query menu, press this button to jump to next selection or decrease value.
			Mute alarm in standby mode or battery mode.
		Touch and hold these two buttons for 2 seconds.	Enter setting mode.





NOTE: If backlight shuts off, you may activate it by touching any button.



13-4. Cold start button (located on the side of the inverter)

- Quick press to wake up inverter when the input power is supplied from battery only.
- Pouch and hold the buttons for 3 seconds to turn on the AC output of the inverter.

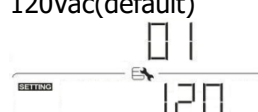
13-5. LCD Setting

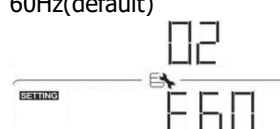
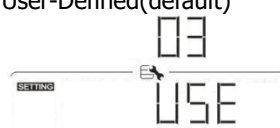
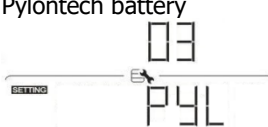
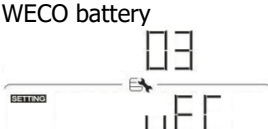

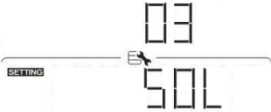
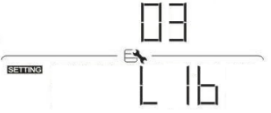
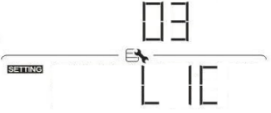
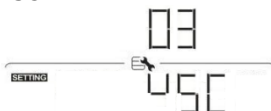
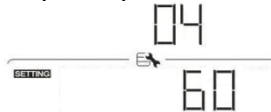

After touching and holding "UP" and "DOWN" button for 2 seconds, the unit will enter setting mode. Press "UP" or "DOWN" button to select setting programs. And then, press "ENTER" button to confirm the selection or ESC button to exit.

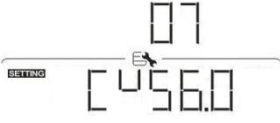
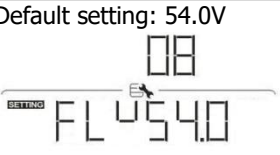
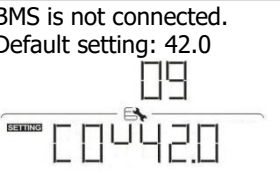
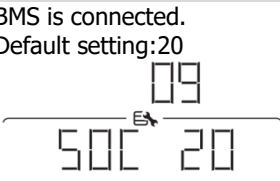
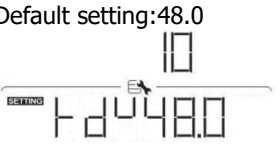
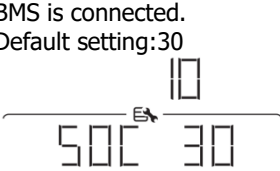
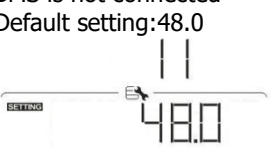

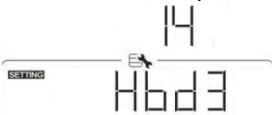
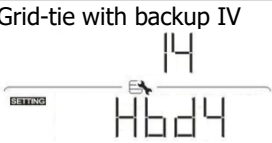

Prog ram	Description	Selectable option	
00	Exit setting mode	Escape 	
01	Output voltage	110Vac 	120Vac(default) 
02	Output frequency	50Hz 	60Hz(default) 
03	Battery type	User-Defined(default) 	If "User Defined" is selected, battery charge voltage and low DC cut off voltage can be set up in program 4, 7, 8 and 9.
		Pylontech battery 	If selected, programs of 4, 7, 8 and 9 will be automatically set up. No need for further setting.
		WECO battery 	If selected, programs of 4, 7, 8 and 9 will be auto-configured per battery supplier recommended. No need for further adjustment.
		Soltaro battery	If selected, programs of 4, 7, 8 and 9 will be automatically

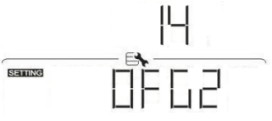

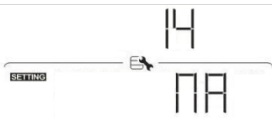

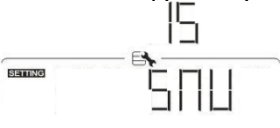
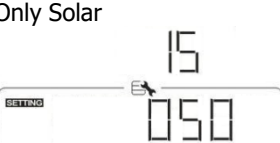
			set up. No need for further setting.
03	Battery type	Lib-protocol compatible battery 	Select "Lib" if using Lithium battery compatible to Lib protocol. If selected, programs of 4, 7, 8 and 9 will be automatically set up. No need for further setting.
		3 rd party Lithium battery 	If selected, programs of 4, 7, 8 and 9 will be automatically set up. No need for further setting. Please contact the battery supplier for installation procedure.
		VSC 	If selected, standard CAN protocol will be supported.
04	Maximum charging current: To configure total charging current for solar and utility chargers. (Max. charging current = utility charging current + solar charging current)	60A(default) 	Setting range is 1A, then from 10A to 120A. Increment of each click is 10A.
05	Maximum utility charging current	30A(default) 	Setting range is from 10A to 120A. Increment of each click is 10A.
06	Maximum discharging current when grid is available	150A(default) 	Setting range is from 10A to 150A. Increment of each click is 10A.
07	Bulk charging	Default setting: 56.0V	Setting range is from 48.0V

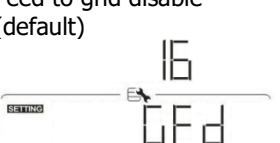
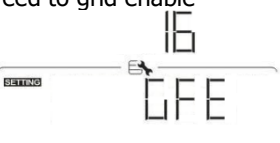
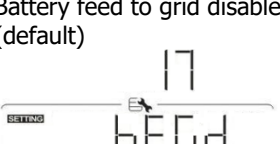
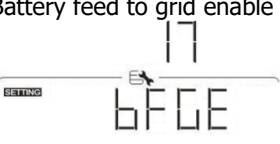
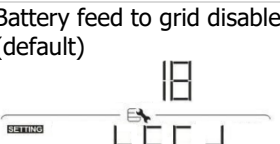
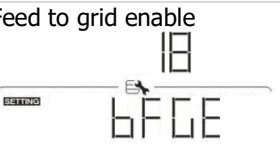
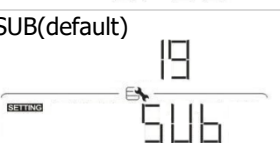
	voltage (C.V voltage)		to 62.0V. Increment of each click is 0.1V.
08	Floating charging voltage	<p>Default setting: 54.0V</p> 	<p>Setting range is from 48.0V to 62.0V. Increment of each click is 0.1V.</p> <p>Note: This setting value must not exceed the C.V voltage.</p>
09	Low DC cut off battery voltage setting or battery SOC when grid is unavailable	<p>BMS is not connected. Default setting: 42.0</p> 	<p>Setting range is from 42.0V to 62.0V. Increment of each click is 0.1V.</p> <p>Note: This setting value must not exceed the C.V voltage.</p>
		<p>BMS is connected. Default setting:20</p> 	<p>Setting range is from 0% to 80%. Increment of each click is 1%.</p>
10	Battery re-discharging voltage or battery SOC when grid is unavailable	<p>BMS is not connected. Default setting:48.0</p> 	<p>Setting range is form 42.0V to 62.0V. Increment of each click is 0.1V.</p> <p>Note: This setting value must not exceed the C.V voltage.</p>
		<p>BMS is connected. Default setting:30</p> 	<p>Setting range is from 0% to 80%. Increment of each click is 1%.</p>
11	Low DC cut off battery voltage or battery SOC when grid is available	<p>BMS is not connected Default setting:48.0</p> 	<p>Setting range is from 40.0V to 62.0V voltage. Increment of each click is 0.1V.</p> <p>Note: This setting value must not exceed the C.V voltage.</p>
		<p>BMS is connected Default setting:30</p>	<p>Setting range is from 5% to 95%. Increment of each click is 1%.</p>



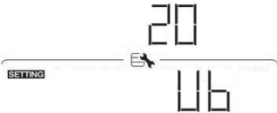
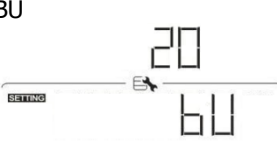



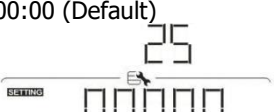
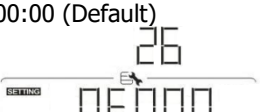

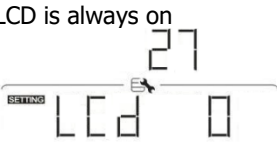
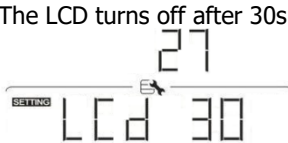
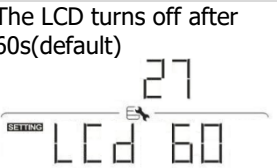
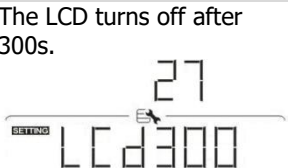
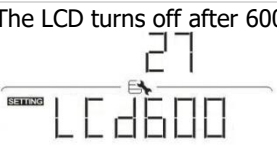
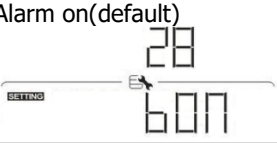
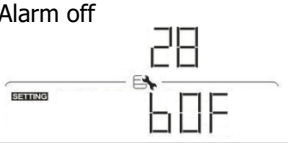
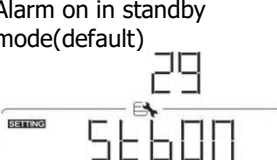
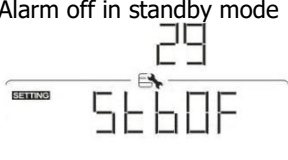
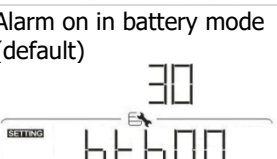
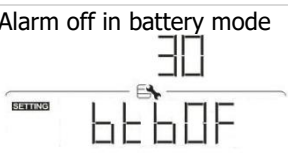
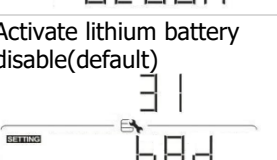
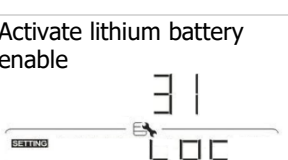
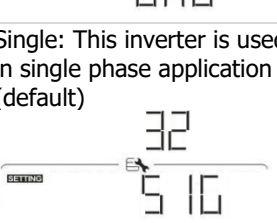
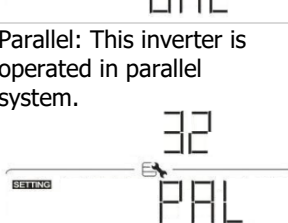
12	Battery re-discharging voltage or battery SOC when grid is available	<p>BMS is not connected. Default setting:54.0</p>	<p>Setting range is from 40.0V to 62.0V voltage. Increment of each click is 0.1V. Note: This setting value must not exceed the C.V voltage.</p>
		<p>BMS is connected. Default setting:40</p>	<p>Setting range is from 5% to 100%. Increment of each click is 1%.</p>
13	Operation Mode (Refer to Section 12 for the detailed operation)	<p>Grid-tie with backup</p>	PV power can feed-in back to grid, provide power to the load and charge battery.
		<p>Off-Grid</p>	PV power only provides power to the load and charge battery. No feed-in back to grid is allowed.
		<p>Grid-Tie</p>	PV power only can feed-in back to grid.
14	PV energy supply priority setting	<p>Grid-tie with backup Mode</p> <p>Grid-tie with backup I</p>	Battery-Load-Grid: PV power will charge battery first, then provide power to the load. If there is any remaining power left, it will feed-in to the grid.
		<p>Grid-tie with backup II</p>	Load-Battery-Grid: PV power will provide power to the load first. Then, it will charge battery. If there is any remaining power left, it will feed-in to the grid.

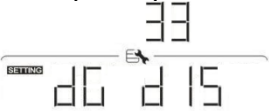
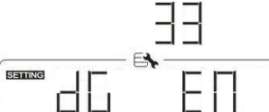
14	PV energy supply priority setting	<p>Grid-tie with backup III</p> 	<p>Load-Grid-Battery: PV power will provide power to the load first. If there is more PV power available, it will feed-in to the grid. If feed-in power reaches max. feed-in power setting, the remaining power will charge battery.</p>
		<p>Grid-tie with backup IV</p> 	<p>If selected, it is only allowed to set up peak time and off-peak for electricity demand. Programs of 15, 17, 18, 19 and 20 can't be set and only programs of 21, 22, 23 and 24 can be set.</p>
		<p>Off-Grid Mode</p>	
		<p>Off-Grid I</p> 	<p>Load-Battery: PV power will provide power to the load first and then charge battery. Feed-in to the grid is not allowed under this mode. At the same time, the grid relay is</p>
		<p>Off-Grid II</p> 	<p>Battery-Load: PV power will charge battery first. After battery is fully charged, if there is remaining PV power left, it will provide power to the load. Feed-in to the grid is not allowed under this mode. At the same time, the grid relay is connected.</p>
		<p>Off-Grid III</p> 	<p>Load-Battery: PV power will provide power to load first and then charge battery. Feed-in to the grid is not allowed under this mode. The grid relay is NOT connected.</p>
		<p>Grid-Tie Mode</p> 	<p>PV power only feeds-in to the grid. No priority setting is available.</p>

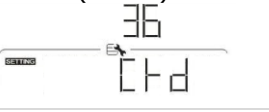
15	Charger source priority	Solar and Utility(default) 	If there is remaining PV power after supporting the loads, it will charge battery first. Only until PV power is not available, grid will charge battery.
		Only Solar 	It is only allow PV power to charge battery.
		None 	It is not allowed to charge battery no matter it's PV power or grid.
16	Feed to grid function	Feed to grid disable (default) 	Feed to grid enable 
		Battery energy feed to grid function when PV energy is available 	Battery feed to grid enable 
18	Battery energy feed to grid function when PV energy is unavailable.	Battery feed to grid disable (default) 	Feed to grid enable 
19	Load supply source (PV is available)	SUB(default) 	Solar-grid-battery: PV power will provide power to the load first. If it's not sufficient, grid will provide power to the load. If grid is not available at the same time, battery power will back up.
		SBU 	Solar-Battery-Grid: PV power will provide power to the load first. If it's not sufficient, battery power will provide power to the load.

			When battery power is running out or not available, grid will back up the load.
20	Load supply source (PV is unavailable)	UB(default) 	Grid-Battery: Grid will provide power to the load at first. If grid is not available, battery power will provide power backup.
		BU 	Battery-Grid: Battery power will provide power to the load at first. If battery power is running out, grid will back up the load. This setting is ineffective during of AC charging.
21	Start charging time for first duration of AC charge	00:00 (Default) 	The setting range of start charging time for AC charger is from 00:00 to 23:00. Increment of each click is 1 hour.
22	Stop charging time for first duration of AC charge	00:00 (Default) 	The setting range of stop charging time for AC charger is from 00:00 to 23:00. Increment of each click is 1 hour.
23	Start charging time for second duration of AC charge	00:00 (Default) 	The setting range of start charging time for AC charger is from 00:00 to 23:00. Increment of each click is 1 hour.
24	Stop charging time for second duration of AC charge	00:00 (Default) 	The setting range of start charging time for AC charger is from 00:00 to 23:00. Increment of each click is 1 hour.
25	Scheduled time for AC output on	00:00 (Default) 	The setting range of AC output on is from 00:00 to 23:00. Increment of each click is 1 hour.
26	Scheduled time for AC output off	00:00 (Default) 	The setting range of AC output off is from 00:00 to 23:00. Increment of each click is 1 hour.

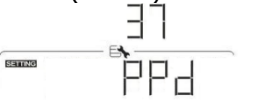
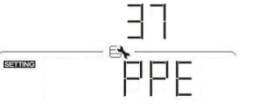
27	LCD off waiting time	LCD is always on 	The LCD turns off after 30s 
		The LCD turns off after 60s(default) 	The LCD turns off after 300s. 
		The LCD turns off after 600s 	
28	Alarm control	Alarm on(default) 	Alarm off 
29	Alarm control at standby mode	Alarm on in standby mode(default) 	Alarm off in standby mode 
30	Alarm control at battery mode	Alarm on in battery mode (default) 	Alarm off in battery mode 
31	Activate lithium battery when the device is powered on	Activate lithium battery disable(default) 	Activate lithium battery enable 
32	AC output mode	Single: This inverter is used in single phase application (default) 	Parallel: This inverter is operated in parallel system. 

33	Generator as AC source	Disable(default) 	Enable 
34	Wide AC input range	Disable (default) 	The protection range for mains voltage is 84V-132V, and the protection range for frequency is 58.5Hz-61.2Hz at 60Hz system or 47.5Hz-52Hz at 50Hz system.
		Enable 	The protection range of the mains voltage is 85V-140V, and the protection range of the frequency is 55Hz-65Hz at 60Hz system or 40Hz-55Hz at 50Hz system.
36	External CT function (Refer to Appendix II for the details)	Disable (default) 	SINGLE 50A 
		PARALLEL 50A 	SINGLE 200A 
		PARALLEL 200A 	
37	PV parallel *This setting is to determine whether PV1 and PV2 can be connected to the same PV source.	Disable(default) 	Enable 
38	AC coupling (Refer to Appendix V for the detail)	Disable(default) 	If selected, there is no output voltage from generator port of hybrid inverter.
		Enable	If selected, there is output voltage from generator port

		<p>The LCD display shows the number '38' at the top and 'OCE' below it. A horizontal line is above '38' and another below 'OCE'. A cursor is positioned to the right of '38'.</p>	of hybrid inverter.
39	Generator port Function (Refer to Appendix III for the details)	Disable(default) <p>The LCD display shows '39' at the top and 'd15' below it. A horizontal line is above '39' and another below 'd15'. A cursor is positioned to the right of '39'.</p>	If selected, the input of generator port will be disabled.
		Enable <p>The LCD display shows '39' at the top and 'GEN' below it. A horizontal line is above '39' and another below 'GEN'. A cursor is positioned to the right of '39'.</p>	If selected, generator port will be activated.
40	L1 and L2 phase angle *Please turn off the inverter output before setting.	120 <p>The LCD display shows '40' at the top and '120' below it. A horizontal line is above '40' and another below '120'. A cursor is positioned to the right of '40'.</p>	180(default) <p>The LCD display shows '40' at the top and '180' below it. A horizontal line is above '40' and another below '180'. A cursor is positioned to the right of '40'.</p>
41	Rapid Shutdown Function (optional, refer to Appendix IV for the details)	Disable(default) <p>The LCD display shows '41' at the top and 'd15' below it. A horizontal line is above '41' and another below 'd15'. A cursor is positioned to the right of '41'.</p>	If selected, RSD dry contact will be idle.
		Enable <p>The LCD display shows '41' at the top and 'ENA' below it. A horizontal line is above '41' and another below 'ENA'. A cursor is positioned to the right of '41'.</p>	If selected, close the RSD dry contact, the machine will shut down the output and stop working. Disconnect the dry contact and the machine will return to its pre-closure state.
95	Time setting – Minute	<p>The LCD display shows '95' at the top and '00' below it. A horizontal line is above '95' and another below '00'. A cursor is positioned to the right of '95'.</p>	For minute setting, the range is from 00 to 59.
96	Time setting – Hour	<p>The LCD display shows '96' at the top and '00' below it. A horizontal line is above '96' and another below '00'. A cursor is positioned to the right of '96'.</p>	For hour setting, the range is from 00 to 23.
97	Time setting– Day	<p>The LCD display shows '97' at the top and '01' below it. A horizontal line is above '97' and another below '01'. A cursor is positioned to the right of '97'.</p>	For day setting, the range is from 00 to 31.
98	Time setting– Month	<p>The LCD display shows '98' at the top and '01' below it. A horizontal line is above '98' and another below '01'. A cursor is positioned to the right of '98'.</p>	For month setting, the range is from 01 to 12.

99	Time setting – Year		For year setting, the range is from 17 to 99.
----	---------------------	-----------------------------------------------------------------------------------	-----------------------------------------------

13-5. Query Menu Operation

The display shows current contents that have been set. The displayed contents can be changed in query menu via button operation. Press 'Enter' button to enter query menu. There are seven query selections:

- Input voltage or frequency of AC input.
- Frequency, voltage, power or load percentage of AC output.
- Input voltage or power of PV input.
- Battery voltage or capability percentage.

Setting Display Procedure

- **Input voltage or frequency of AC input**

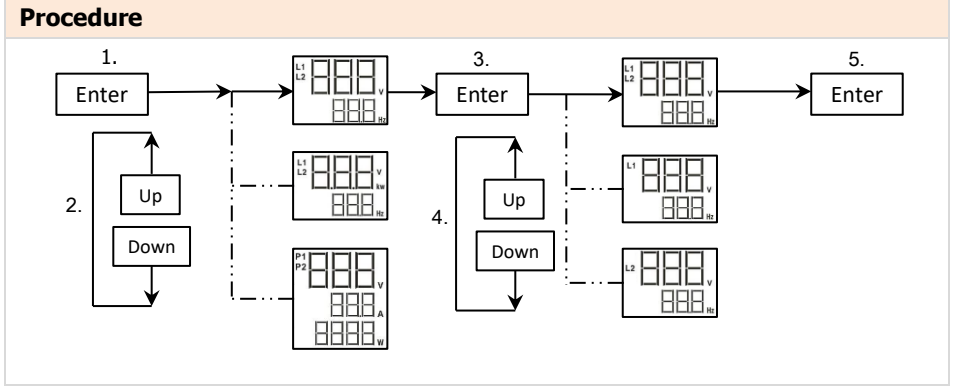

- **Frequency, voltage, power or percentage of AC output**

Procedure

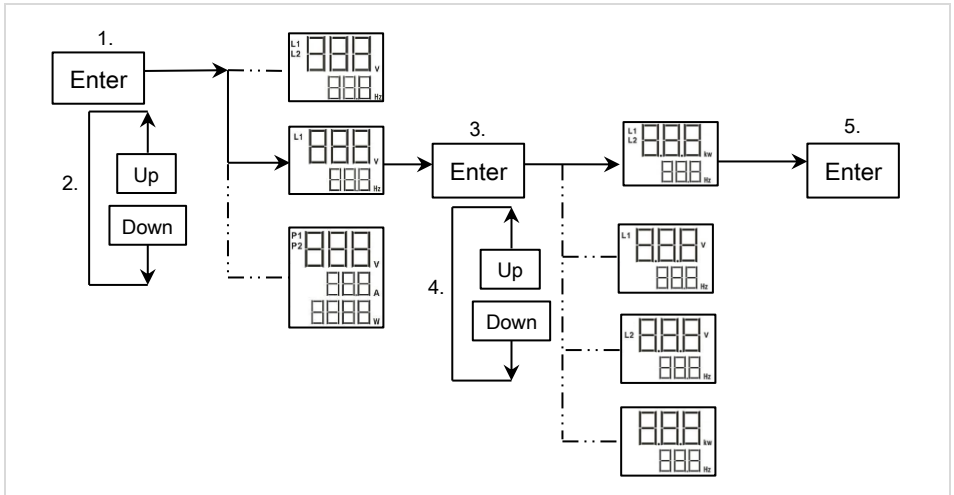

● **Input voltage or power of PV input.**

Procedure

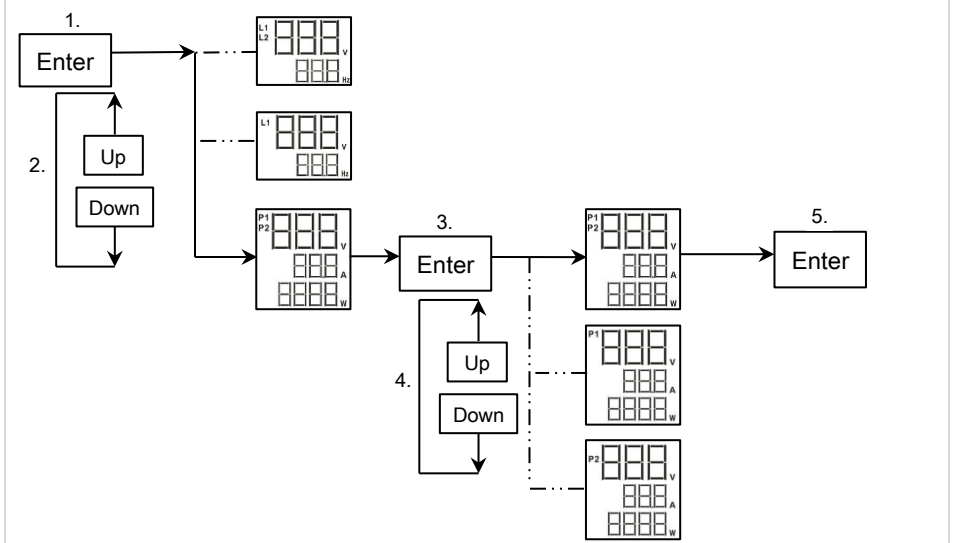

Switch LCD Displayed Information

The LCD display information will be switched in turns by pressing "▲" or "▼" key. The selectable information is switched as the following table in order.

Selectable information	LCD display
Real date	Real date: 2020-08-18

	<p>CV 560 V CHARGING 10 A LOAD BATT 75 50 25 AC OUTPUT 120 V 500 Hz L1 P1 400 V 100 A 4000 W DAY 2008.18</p>
Real time	<p>Real time: 10:08</p> <p>CV 560 V CHARGING 10 A LOAD BATT 75 50 25 AC OUTPUT 120 V 500 Hz L1 P1 400 V 100 A 4000 W DAY 10:08</p>
PV energy generated today.	<p>PV energy generated this month = 8Wh.</p> <p>CV 560 V CHARGING 10 A LOAD BATT 75 50 25 AC OUTPUT 120 V 500 Hz L1 P1 400 V 100 A 4000 W DAY 8 Wh</p>
PV energy generated this month.	<p>PV energy generated this month = 8kWh.</p>

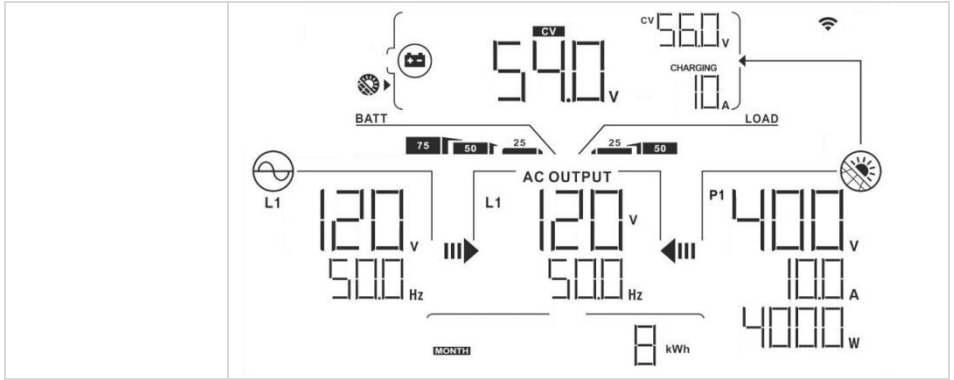

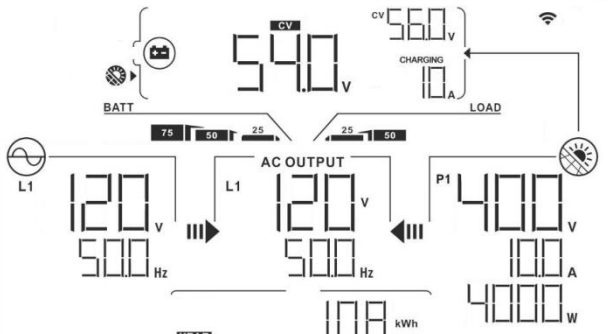
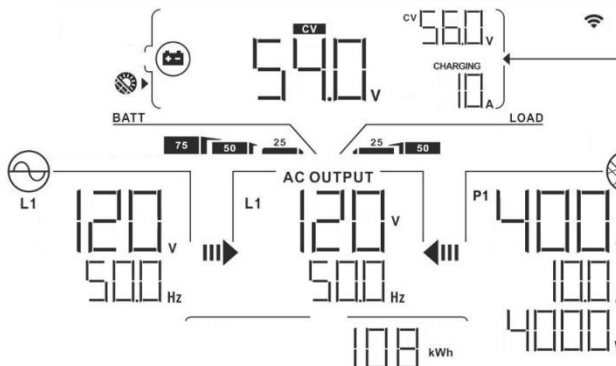
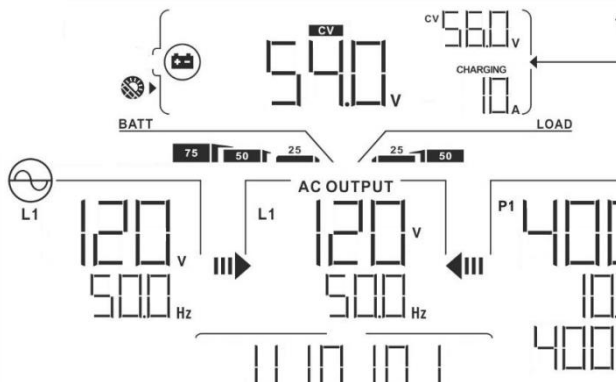
<p>PV energy generated this year.</p>	<p>PV energy generated this year = 108kWh</p> 
<p>PV energy generated totally.</p>	<p>Total PV energy generation = 108kWh.</p> 
<p>Main CPU version checking</p>	<p>Main CPU version 01.01.</p> 

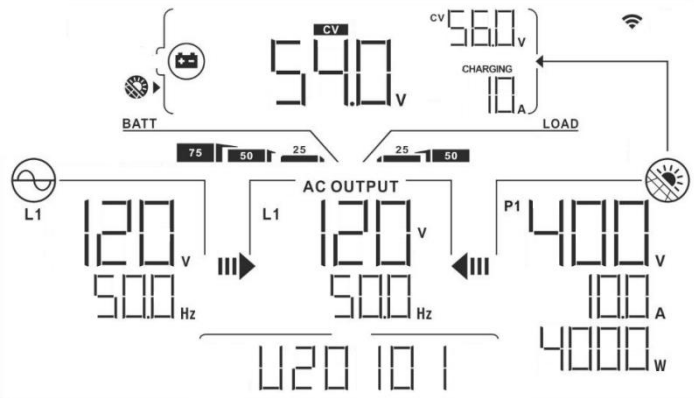
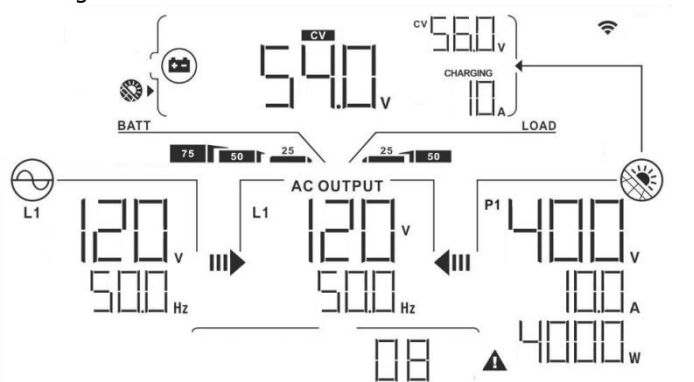
<p>Communication board version checking</p>	<p>Communication board version 01.01.</p> 
<p>Warning code</p>	<p>Warning code: 08</p> 

13-6. Operation Mode & Display

Below is only contained LCD display for **grid-tie with backup mode (I)**. If you need to know other operation mode with LCD display, please check with installer.

Inverter mode with grid connected

This inverter is connected to grid and working with DC/INV operation.

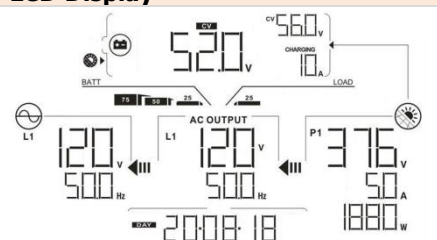
LCD Display	Description
	<p>PV power is sufficient to charge battery, provide power to loads, and then feed in to the grid.</p>

<p>Diagram 1: PV power is sufficient to charge the battery first. However, remaining PV power is not sufficient to back up the load. Therefore, remaining PV power and the utility are supplying power to the connected load.</p> <p>Panel status: BATT (75%), AC OUTPUT (25%), CHARGING (10%), LOAD (25%).</p> <p>Grid voltage: 120 V, 500 Hz. PV output: 520 V. Load voltage: 376 V, 50 A, 1880 W. Utility output: 420 V.</p> <p>Time: 20:08:18</p>	<p>PV power is sufficient to charge the battery first. However, remaining PV power is not sufficient to back up the load. Therefore, remaining PV power and the utility are supplying power to the connected load.</p>
<p>Diagram 2: PV power is generated, but not sufficient enough to charge battery by itself. PV power and the utility are charging battery at the same time. And the utility is also supplying power to the connected load.</p> <p>Panel status: BATT (75%), AC OUTPUT (25%), CHARGING (20%), LOAD (20%).</p> <p>Grid voltage: 120 V, 500 Hz. PV output: 520 V. Load voltage: 400 V, 20 A, 800 W. Utility output: 420 V.</p> <p>Time: 20:08:18</p>	<p>PV power is generated, but not sufficient enough to charge battery by itself. PV power and the utility are charging battery at the same time. And the utility is also supplying power to the connected load.</p>
<p>Diagram 3: PV power is sufficient to provide power to loads and feed power back to the grid.</p> <p>Panel status: BATT (0%), AC OUTPUT (0%), CHARGING (0%), LOAD (0%).</p> <p>Grid voltage: 120 V, 500 Hz. PV output: 520 V. Load voltage: 400 V, 100 A, 4000 W. Utility output: 420 V.</p> <p>Time: 20:08:18</p>	<p>PV power is sufficient to provide power to loads and feed power back to the grid.</p>
<p>Diagram 4: PV power and utility are providing power to the connected loads because of insufficient PV power.</p> <p>Panel status: BATT (0%), AC OUTPUT (0%), CHARGING (0%), LOAD (0%).</p> <p>Grid voltage: 120 V, 500 Hz. PV output: 520 V. Load voltage: 400 V, 100 A, 4000 W. Utility output: 420 V.</p> <p>Time: 20:08:18</p>	<p>PV power and utility are providing power to the connected loads because of insufficient PV power.</p>
<p>Diagram 5: Only utility is charging battery and providing power to connected loads.</p> <p>Panel status: BATT (75%), AC OUTPUT (25%), CHARGING (20%), LOAD (20%).</p> <p>Grid voltage: 120 V, 500 Hz. PV output: 520 V. Load voltage: 0 V, 0 A, 0 W. Utility output: 420 V.</p> <p>Time: 20:08:18</p>	<p>Only utility is charging battery and providing power to connected loads.</p>

Inverter mode without grid connected

This inverter is working with DC/INV operation and not connecting to the grid.

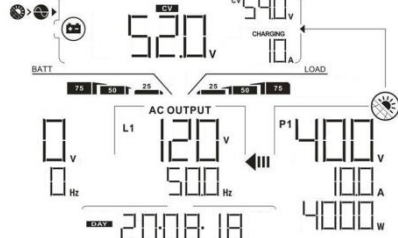
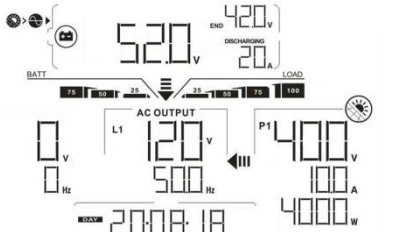
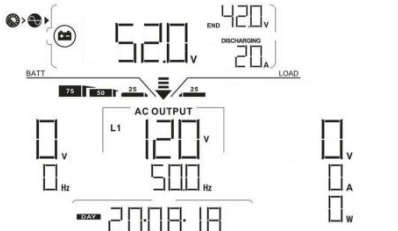
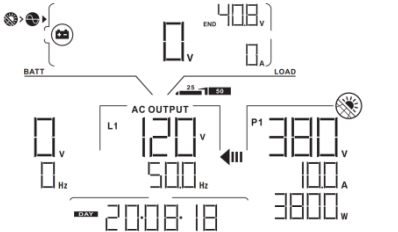
LCD Display	Description
 <p>The LCD display shows the following information:</p> <ul style="list-style-type: none"> DC Input: 520 V, 540 V (CV), 10 A (CHARGING) BATTERY: 75% (BATT), 25% (CHG), 25% (DISCHG), 75% (LOAD) AC Output (L1): 120 V, 500 Hz AC Output (P1): 400 V, 100 A, 4000 W Time: 20:08:18 	<p>PV power is sufficient to charge battery and provide power to the connected loads.</p>
 <p>The LCD display shows the following information:</p> <ul style="list-style-type: none"> DC Input: 520 V, 420 V (END), 20 A (DISCHARGING) BATTERY: 75% (BATT), 25% (CHG), 25% (DISCHG), 75% (LOAD) AC Output (L1): 120 V, 500 Hz AC Output (P1): 400 V, 100 A, 4000 W Time: 20:08:18 	<p>PV power is generated, but not sufficient to power loads by itself. PV power and battery are providing power to the connected loads at the same time.</p>
 <p>The LCD display shows the following information:</p> <ul style="list-style-type: none"> DC Input: 520 V, 420 V (END), 20 A (DISCHARGING) BATTERY: 75% (BATT), 25% (CHG), 25% (DISCHG), 75% (LOAD) AC Output (L1): 120 V, 500 Hz AC Output (P1): 0 V, 0 A, 0 W Time: 20:08:18 	<p>Only battery power is available to provide power to connected loads.</p>
 <p>The LCD display shows the following information:</p> <ul style="list-style-type: none"> DC Input: 0 V, 408 V (END), 0 A (DISCHARGING) BATTERY: 75% (BATT), 25% (CHG), 25% (DISCHG), 75% (LOAD) AC Output (L1): 120 V, 500 Hz AC Output (P1): 380 V, 100 A, 3800 W Time: 20:08:18 	<p>Only PV power supplies power to connected loads. Notice: The inverter doesn't support battery hot pluggable. When the inverter is working with solar input, turn off the inverter first and then connect the battery.</p>

Bypass mode

The inverter is working without DC/INV operation and connecting to the loads.

LCD Display	Description
	<p>Only utility is available to provide power to connected loads.</p>

Standby mode :

The inverter is working without DC/INV operation and load connected.

LCD Display	Description
	<p>This inverter is disabled on AC output or even AC power output is enabled, but an error occurs on AC output. Only PV power is sufficient to charge battery.</p>
	<p>If PV, battery or utility icons are flashing, it means they are not within acceptable working range. If they are not displayed, it means they are not detected.</p>

14. Charging Management

Charging Parameter	Default Value	Note
Charging current	60A	It can be adjusted via software from 5Amp to 120Amp.
Floating charging voltage (default)	54.0 Vdc	It can be adjusted via software from 50Vac to 62Vdc.
Max. absorption charging voltage (default)	56.0 Vdc	It can be adjusted via software from 50Vac to 62Vdc.
Battery overcharge protection	64.0 Vdc	
<p>Charging process based on default setting.</p> <p>3 stages:</p> <p>First – max. charging voltage increases to 56V;</p> <p>Second- charging voltage will maintain at 56V until charging current is down to 12 Amp;</p> <p>Third- go to floating charging at 54V.</p>		

This inverter can connect to battery types of sealed lead acid battery, vented battery, gel battery and lithium battery. The detail installation and maintenance explanations of the external battery pack are provided in the manufacturer's external battery pack of manual.

If using sealed lead acid battery, please set up the max. charging current according to below formula:

$$\text{The maximum charging current} = \text{Battery capacity (Ah)} \times 0.2$$

For example, if you are using 300 Ah battery, then, maximum charging current is $300 \times 0.2=60$ (A). Please use at least 50Ah battery because the settable minimum value of charging current is 10A. If using AGM/Gel or other types of battery, please consult with installer for the details.

Below is setting screen from software:

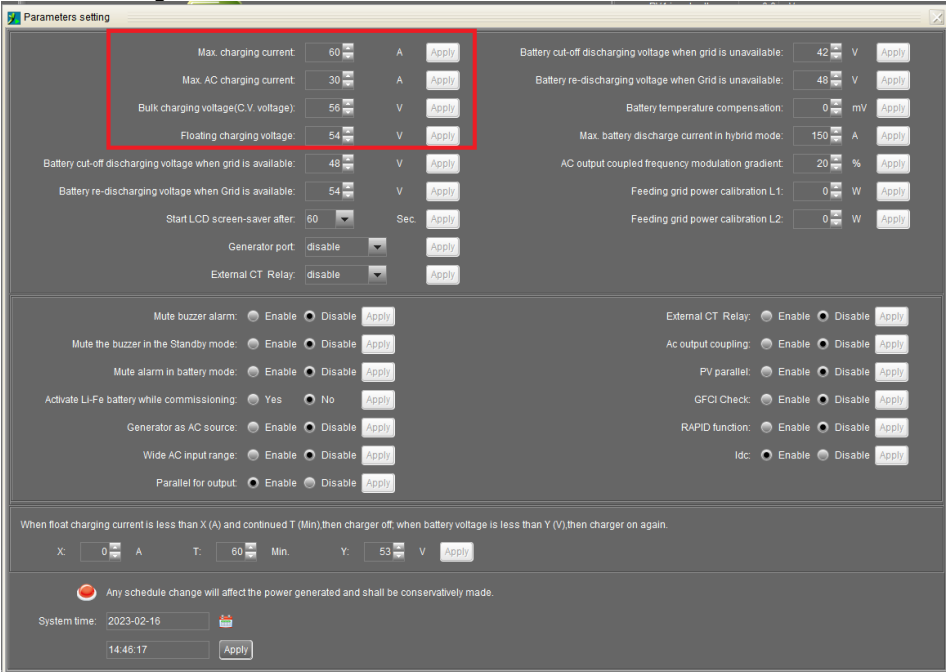

15. Maintenance & Cleaning

Check the following points to ensure proper operation of whole solar system at regular intervals.

- Ensure all connectors of this inverter are cleaned all the time.
- Before cleaning the solar panels, be sure to turn off PV DC breakers.
- Clean the solar panels, during the cool time of the day, whenever it is visibly dirty.
- Periodically inspect the system to make sure that all wires and supports are securely fastened in place.



WARNING! There are no user-replaceable parts inside of the inverter. Do not attempt to service the unit yourself.

Battery Maintenance

- Servicing of batteries should be performed or supervised by personnel knowledgeable about batteries and the required precautions.
- When replacing batteries, replace with the same type and number of batteries or battery packs.
- The following precautions should be observed when working on batteries:
 - a) Remove watches, rings, or other metal objects.
 - b) Use tools with insulated handles.
 - c) Wear rubber gloves and boots.
 - d) Do not lay tools or metal parts on top of batteries.
 - e) Disconnect charging source prior to connecting or disconnecting battery terminals.
 - f) Determine if battery is inadvertently grounded. If inadvertently grounded, remove source from ground. Contact with any part of a grounded battery can result in electrical shock. The likelihood of such shock can be reduced if such grounds are removed during installation and maintenance (applicable to equipment and remote battery supplies not having a grounded supply circuit).



CAUTION! A battery can present a risk of electrical shock and high short-circuit current.

CAUTION! Do not dispose of batteries in a fire. The batteries may explode.

CAUTION! Do not open or mutilate batteries. Released electrolyte is harmful to the skin and eyes. It may be toxic.













16. Trouble Shooting





When there is no information displayed in the LCD, please check if PV module / battery / grid connection is correctly connected.

NOTE: The warning and fault information can be recorded by remote monitoring software.

16-1. Warning List

There are 17 situations defined as warnings. When a warning situation occurs,  icon will flash. Touch "up" or "down" to select displaying warning code. If there are several codes, it will display in sequences. Please contact your installer when you couldn't handle with the warning situations.

Code	Warning Event	Icon (flashing)	Description
01	Line voltage high loss		Grid voltage is too high.
02	Line voltage low loss		Grid voltage is too low.
03	Line frequency high loss		Grid frequency is too high.
04	Line frequency low loss		Grid frequency is too low.
05	Line voltage loss for long time		Grid voltage is higher than 253V.
06	Ground Loss		Ground wire is not detected.
07	Island detect		Island operation is detected.
08	Line waveform loss		The waveform of grid is not suitable for inverter.
09	Line phase loss		The phase of grid is not in right sequence.
11	Overload		Load exceeds rating value.
12	Over temperature		The temperature is too high inside.
13	Batter voltage low		Battery discharges to low alarm point.
14	Battery under-voltage when grid is loss		Battery discharges to shutdown point.
15	Battery open		Battery is unconnected or too low.
16	Battery under-voltage when grid is OK		Battery stops discharging when the grid is OK.
17	Solar over voltage		PV voltage is too high.

18	RSD is close.		RSD is close.
19	The CT function setting of the inverter is set incorrectly in parallel system.		In parallel system, there are multiple inverters with the CT function setting turned on.
20	The fan is stuck.		The fan is stuck.
32	Communication lost between DSP and communication board.		Communication lost between DSP and communication board.
SW OFF	The battery output will not be turned on when Grid is lost.		The battery output will not be turned on when Grid is lost.

16-2. Fault Reference Codes

When a fault occurs, the icon  will flash as a reminder. See below for fault codes for reference.

Situation			
Fault Code	Fault Event	Possible cause	Solution
01	Bus voltage over	Surge	1. Restart the inverter. 2. If the error message still remains, please contact your installer.
02	BUS voltage under	PV or battery disconnect suddenly	1. Restart the inverter 2. If the error message still remains, please contact your installer.
03	BUS soft start time out	Internal components failed.	Please contact your installer.
04	INV soft start time out	Internal components failed.	Please contact your installer.
05	INV over current	Surge	1. Restart the inverter. 2. If the error message still remains, please contact your installer.
06	Over temperature	Internal temperature is too high.	1. Check the ambient temperature and fans. 2. If the error message still remains, please contact your installer.
07	Relay fault	Internal components failed.	Please contact your installer.

08	CT sensor fault	Internal components failed.	Please contact your installer.
09	Solar input power abnormal	1. Solar input driver damaged. 2. Solar input power is too much when voltage is more than 600V.	1. Please check if solar input voltage is higher than 600V. 2. Please contact your installer.
11	Solar over current	Surge	1. Restart the inverter. 2. If the error message still remains, please contact your installer.
12	GFCI fault	Leakage current exceeds the limit.	1. Check the wire and panels which may cause the leakage.
13	PV ISO fault	The resistance between PV and ground is too low.	2. If the error message still remains, please contact your installer.
14	INV DC current over	Utility fluctuates.	1. Restart the inverter. 2. If the error message still remains, please contact your installer.
16	GFCI sensor fault	GFCI sensor failed.	Please contact your installer.
17	DSP and MCU Com. Loss	Communication loss between DSP and MCU	Please contact your installer.
20	The DC-DC CT sample circuit failure	Main board failed.	Replace the main board.
21	The DC-AC CT sample circuit failure	The Grid board failed.	1. Check the cable of the Grid board 2. Replace the Grid board.
22	Battery high voltage fault	Battery voltage exceeds the limit.	1. Check the battery voltage. 2. If the error message still remains, please contact your installer.
23	Over load	The inverter is loaded with more than 110% load and time is up.	Reduced the connected load by switching off some equipment.
26	INV short	Output short circuited.	Check if wiring is connected well and remove abnormal load.
27	Fan lock	Fan failed.	Please contact your installer.
32	DC/DC over current	Battery voltage	1. Restart the inverter.

		fluctuates.	2. If the error message still remains, please contact your installer.
33	INV voltage low	Internal components failed.	Please contact your installer.
34	INV voltage high	Internal components failed.	Please contact your installer.
35	Wire connection fault	Internal wires loosen.	Please contact your installer.
36	OP voltage fault	Grid connects to output terminal	Don't connect the grid to the output terminal.
38	Short circuited on PV input	Short circuited on PV input	Please contact your installer.
47	The L1/L2 of the inverter is short-circuited.	Output short circuited.	Check if all wiring is connected well and remove abnormal loads.
60	Current feedback into the inverter is detected.		<ol style="list-style-type: none"> 1. Restart the inverter. 2. Check if L1/L2/N cables are not connected with wrong sequence in all inverters. 3. Make sure the sharing cables are connected in all inverters. 4. If the problem remains, please contact your installer.
71	The firmware version of each inverter is not the same.	Software differences do not support parallel.	<ol style="list-style-type: none"> 1. Update all inverter firmware to the same version. 2. After updating, if the problem still remains, please contact your installer.
72	The output current of each inverter is different.		<ol style="list-style-type: none"> 1. Check if sharing cables are connected well and restart the inverter. 2. If the problem remains, please contact your installer.
80	CAN data loss		<ol style="list-style-type: none"> 1. Check if communication cables are connected well and restart the inverter. 2. If the problem remains, please contact your installer.
81	Host data loss		
82	Synchronization data loss		
88	BUS Balances overcurrent	Internal components failed.	Please contact your installer.
89	BUS balance	Internal	Please contact your installer.

	hardware Fault	components failed.	
--	----------------	--------------------	--

17. Specifications

Model	GP6K7.5PV-US-GE
RATED POWER	6000 W
PV INPUT (DC)	
Max. DC Power	7500 W
Nominal DC Voltage	360 VDC
Max. DC Voltage	600 VDC
Working DC Voltage Range	120 VDC ~ 550 VDC
Start-up Voltage / Initial Feeding Voltage	125 VDC / 160 VDC
MPP Voltage Range	120 VDC ~ 550 VDC
Max. Input current	2*15 A
Isc PV (absolute maximum)	21 A
Max. inverter back feed current to the array	0 A
AC INPUT	
AC Start-up Voltage	85 VAC per phase
Auto Restart Voltage	90 VAC per phase
Acceptable Input Voltage Range	85 - 140 VAC per phase
Nominal Frequency	50 Hz / 60 Hz
AC Input Power	6000VA/6000W
Maximum AC Input Current	40 A
Inrush Input Current	40 A / 1ms
GRID OUTPUT (AC)	
Nominal Output Voltage	120 VAC (P-N) / 208 VAC (P-P)/ 240 VAC(P-P)
Output Voltage Range	105.5 - 132 VAC per phase
Output Frequency Range	47.5 ~ 51.5 Hz or 59.3~ 60.5Hz
Nominal Output Current	25A per phase
Inrush Current/Duration	30 A per phase / 20ms
Maximum Output Fault Current/Duration	81 A per phase / 1ms
Maximum Output Overcurrent Protection	81 A per phase
Power Factor Range	0.9 lead – 0.9 lag
BATTERY MODE OUTPUT (AC)	
Nominal Output Voltage	120 VAC (P-N) / 208 VAC (P-P)/ 240 VAC(P-P)
Output Frequency	50 Hz / 60 Hz (auto sensing)
Output Waveform	Pure sine wave
Output Power	6000VA/6000W
Efficiency (DC to AC)	91%
BATTERY & CHARGER (Lead-acid/Li-ion)	
DC Voltage Range	40 – 62 VDC
Nominal DC Voltage	48 VDC

Maximum Battery Discharging Current	150 A
Maximum Charging Current	120 A
GENERAL	
PHYSICAL	
Dimension, D X W X H (mm)	225 x 515 x 700
Net Weight (kgs)	41
INTERACE	
Communication Port	RS-232/USB
Intelligent Slot	RS232/USB,BMS, WIFI
ENVIRONMENT	
Protective Class	I
Ingress Protection Rating	IP65
Humidity	0 ~ 90% RH (No condensing)
Operating Temperature	-25 to 60°C (Power derating above 45°C)
Altitude	Max. 2000m*

* Power derating 1% every 100m when altitude is over 1000m.

Appendix I: Parallel Installation Guide

Introduction

This inverter can be used in parallel with maximum 6 units. The supported maximum output power is 36KW/36KVA.

Parallel cable

You will find the following items in the package:



Parallel communication cable



Current sharing wires

Overview

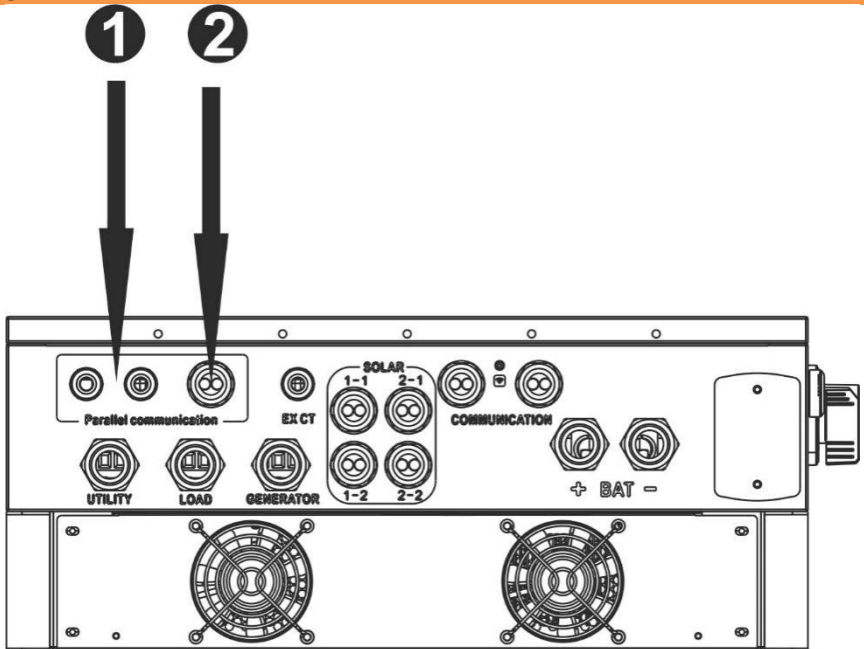

1. Current sharing port
2. Parallel communication port

Mounting the Unit

When installing multiple units, please follow below chart.

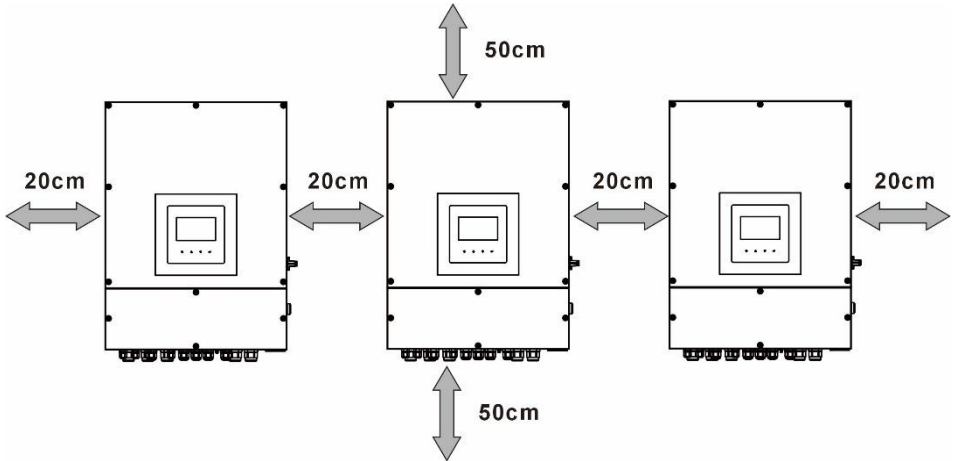

NOTE: For proper air circulation to dissipate heat, it's necessary to allow a clearance of approx. 20 cm to the side and approx. 50 cm above and below the unit. Be sure to install each unit in the same level.

Wiring Connection

The cable size of each inverter is shown as below:

Recommended battery cable and terminal size for each inverter:

Wire Size	Cable mm ²	Terminal Dimensions			Torque value
		E (mm)	W (mm)	L (mm)	
1/0 AWG	53.5	8.4	16	45.5	5 Nm

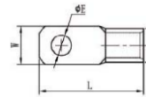

WARNING: Be sure the length of all battery cables is the same. Otherwise, there will be voltage difference between inverter and battery to cause parallel inverters not working.

Recommended AC input and output cable size for each inverter:

AWG no.	Conductor cross-section	Torque
10~8 AWG	5.5~10 mm ²	1.4~1.6Nm

You need to connect the cables of each inverter together. Take the battery cables for

example. You need to use a connector or bus-bar as a joint to connect the battery cables together, and then connect to the battery terminal. The cable size used from joint to battery should be X times cable size in the tables above. "X" indicates the number of inverters connected in parallel.

Regarding cable size of AC input and output, please also follow the same principle.



CAUTION!! Please install a breaker at the battery side. This will ensure the inverter can be securely disconnected during maintenance and fully protected from overcurrent of battery.

Recommended breaker specification of battery for each inverter:

One unit*
200A/60VDC

*If you want to use only one breaker at the battery side for the whole system, the rating of the breaker should be X times current of one unit. "X" indicates the number of inverters connected in parallel.

Recommended battery capacity

Inverter parallel numbers	2	3	4	5	6
Battery Capacity	400AH	600AH	800AH	1000AH	1200AH

CAUTION! Please follow the battery charging current and voltage from battery spec to choose the suitable battery. The wrong charging parameters will reduce the battery lifecycle sharply.

Approximate back-up time table

Load (W)	Backup Time @ 48Vdc 400Ah (min)	Backup Time @ 48Vdc 600Ah (min)	Backup Time @ 48Vdc 800Ah (min)	Backup Time @ 48Vdc 1000Ah (min)	Backup Time @ 48Vdc 1200Ah (min)
12000	90	140	180	240	280
18000	60	90	120	160	180
24000	40	70	90	120	140
30000	35	55	75	90	110
36000	30	50	60	80	100

PV Connection

Please refer to user manual of single unit for PV Connection.

CAUTION: Each inverter should connect to PV modules separately.

Inverters Configuration

Two inverters in parallel:

Power Connection

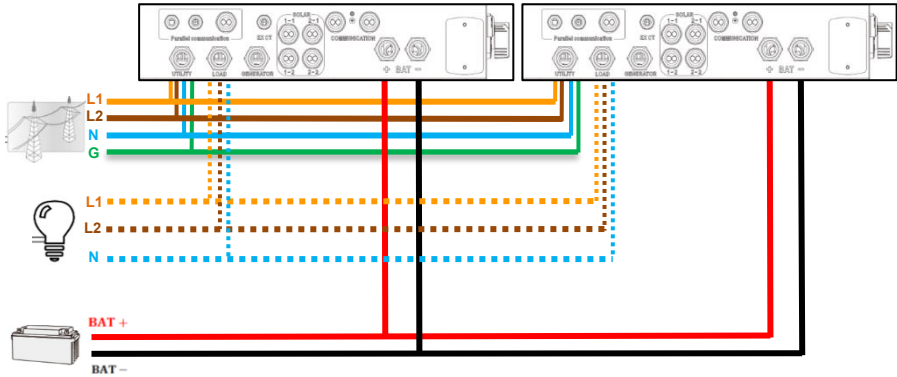

Communication Connection

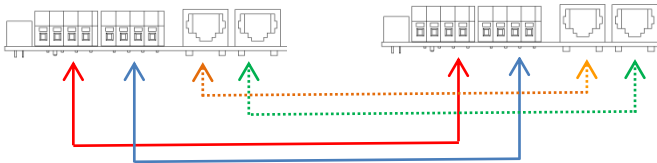

Three inverters in parallel:

Power Connection

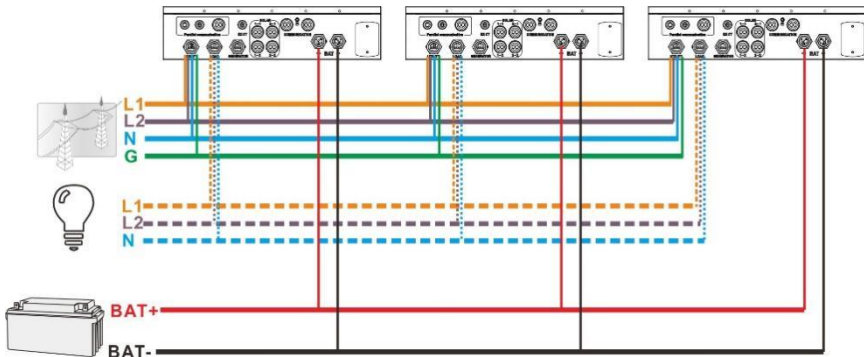

Communication Connection

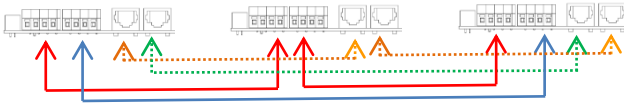

Four inverters in parallel:

Power Connection

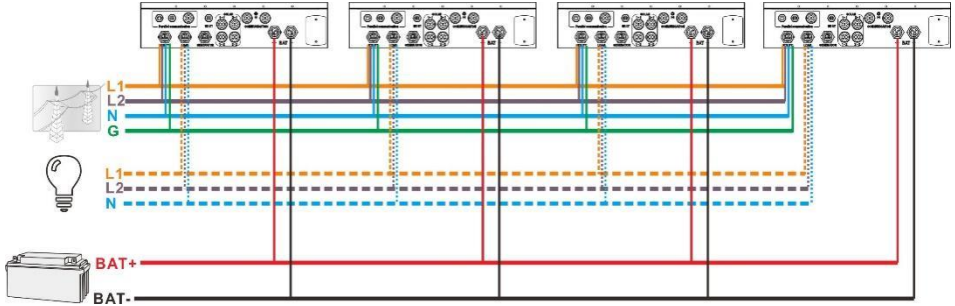

Communication Connection



Five inverters in parallel:

Power Connection

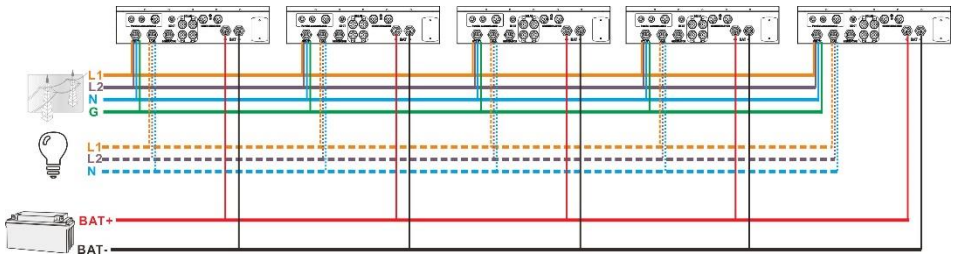

Communication Connection

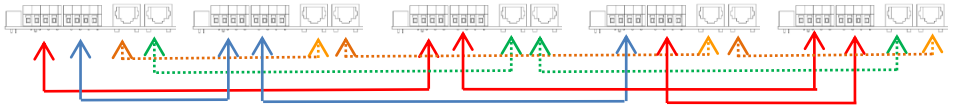

Six inverters in parallel:

Power Connection

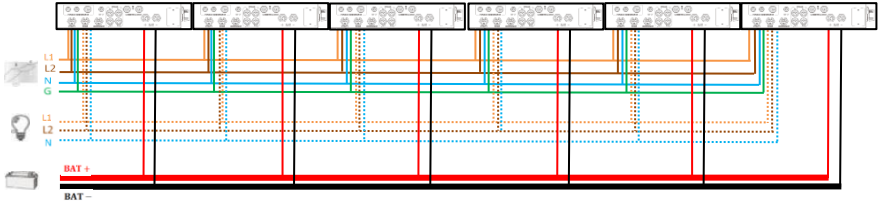

Communication Connection

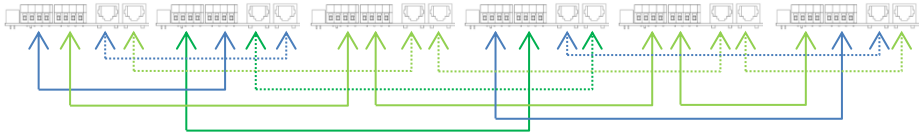

Setting and LCD Display



Setting Program:

The parallel function setting can be set up through software or LCD setting #32. When setting through software, you can set the inverter one by one through USB or RS-232 port.

- Through software:
Setting parallel for output in parameters setting, enable/disable.

The screenshot shows the 'Parameters setting' window with various configuration options. The 'Parallel for output' option is highlighted with a red box and is currently set to 'Enable'. Other visible options include Max. charging current (60 A), Max. AC charging current (30 A), Bulk charging voltage (56 V), Floating charging voltage (54 V), Battery cut-off discharging voltage when grid is available (48 V), Battery re-discharging voltage when Grid is available (54 V), Start LCD screen-saver after (60 Sec), Generator port (disable), External CT Relay (disable), Battery cut-off discharging voltage when grid is unavailable (42 V), Battery re-discharging voltage when Grid is unavailable (48 V), Battery temperature compensation (0 mV), Max. battery discharge current in hybrid mode (150 A), AC output coupled frequency modulation gradient (20 %), Feeding grid power calibration L1 (0 W), Feeding grid power calibration L2 (0 W), Mute buzzer alarm (Disable), Mute the buzzer in the Standby mode (Disable), Mute alarm in battery mode (Disable), Activate Li-Fe battery while commissioning (No), Generator as AC source (Disable), Wide AC input range (Disable), External CT Relay (Disable), AC output coupling (Disable), PV parallel (Disable), GFCI Check (Disable), RAPID function (Disable), and Idc (Disable).

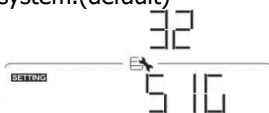
- Through LCD operation
In LCD program 32, you may select single or parallel.

32	Parallel for output	Single: This inverter is operated in Single system.(default) 	Parallel: This inverter is operated in parallel system. 
----	---------------------	-----------------------------------------------------------------------------------------------------------------------------------------------------	-------------------------------------------------------------------------------------------------------------------------------------------------

Commissioning

Step 1: Check the following requirements before commissioning:

- Check if all wires area connected correctly.
- Ensure all breakers in Line wires of load side are open and each Neutral wire of each unit is connected together.

Step 2: Turn on each unit and set "enable parallel for output" on SolarPower or SolarPower Pro. Or set "PAL" in LCD program 32. And then, shut down all units.

Step 3: Turn on each unit.

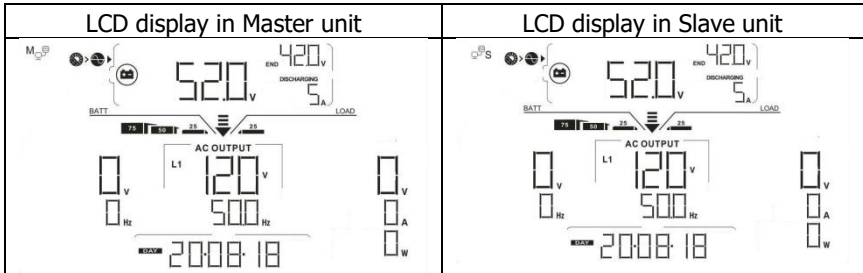

NOTE: Master and slave units are randomly defined.

Step 4: Switch on all AC breakers of Line wires in AC input. It's better to have all inverters connect to utility at the same time. If not, it will display fault 82 in following-order inverters. However, these inverters will automatically restart. If AC power is detected, they will work normally.

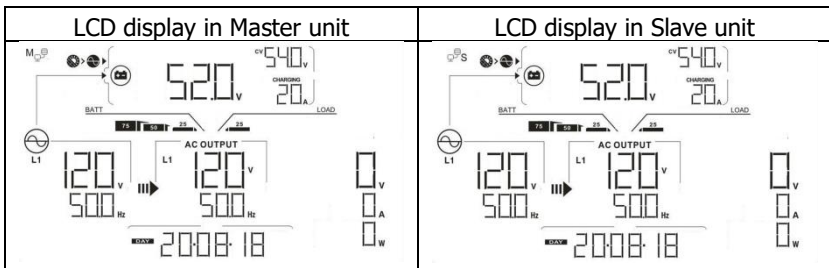

Step 5: If there is no more fault alarm, the parallel system is completely installed.

Step 6: Please switch on all breakers of Line wires in load side. This system will start to provide power to the load.

Appendix II: The CT Operation Guide

With CT connected, solar inverter can be easily integrated into the existing household system. It's to arrange self-consumption via CT to control power generation and battery charging of the inverter.

Single commissioning

Step 1. Power off the inverter and connect the CT sensor according to the wiring diagram below. The red wire of the CT sensor is connected to the "+" on the CT board and the white wire of the CT Sensor is connected to the "-" on the CT board

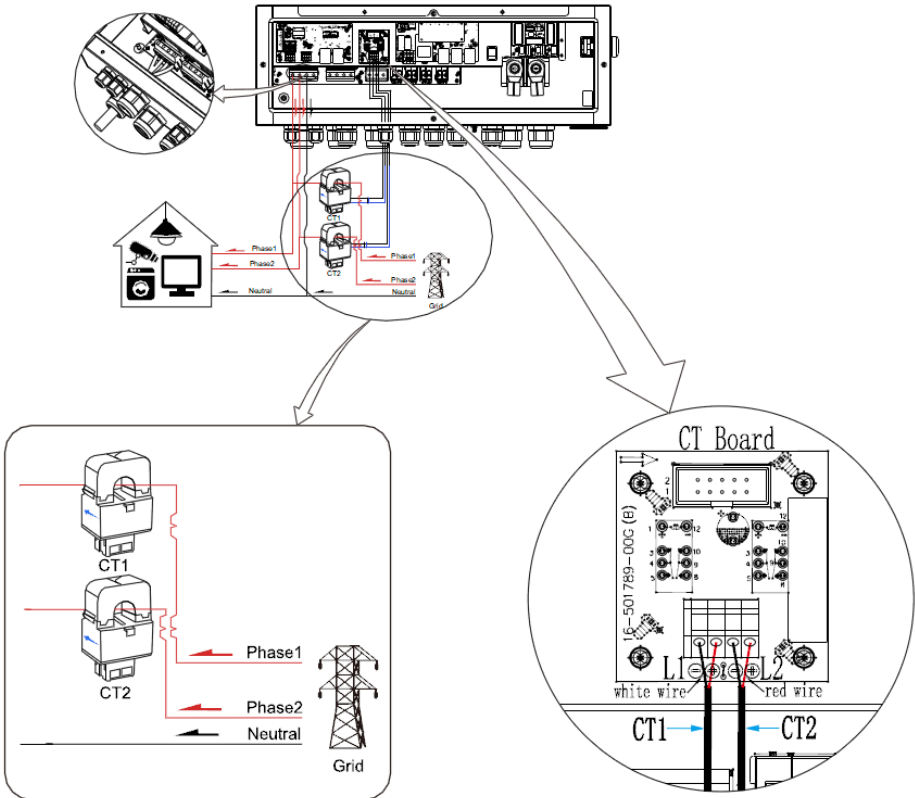



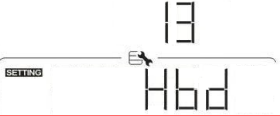

NOTE:

1. The arrow is printed on the CT sensor. Please check the direction of the CT sensor.
2. CT Board is printed with '+' and '-'. Please connect the red wire of the CT sensor with '+' and the white wire with '-'

Step 2: Power on the inverter, wake up the LCD and modify LCD setting. Enter LCD setting #13 and set up as any Grid-tie with backup mode. The CT will not be enable if not setting to grid-tie with backup.

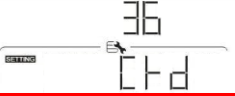
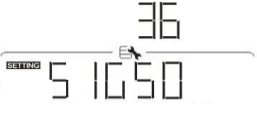
13	Operation Mode (Refer to section 12 for the details.)	<p>Grid-tie with backup</p> 	PV power can feed-in back to grid, provide power to the load and charge battery.
----	-------------------------------------------------------	---------------------------------------------------------------------------------------------------------------	----------------------------------------------------------------------------------

Step 3: Enter LCD setting #36 and select "single 50A" or "single 200A" based on your CT specifications.

36	External CT function	<p>Disable (default)</p> 	
		<p>SINGLE 50A</p> 	<p>PARALLEL 50A</p> 
		<p>SINGLE 200A</p> 	<p>PARALLEL 200A</p> 

Parallel commissioning

Step 1. Power off the inverter and connect the CT sensor according to the wiring diagram below. If applying CT function during parallel operation, it only needs one inverter from parallel system connected to CT sensor.

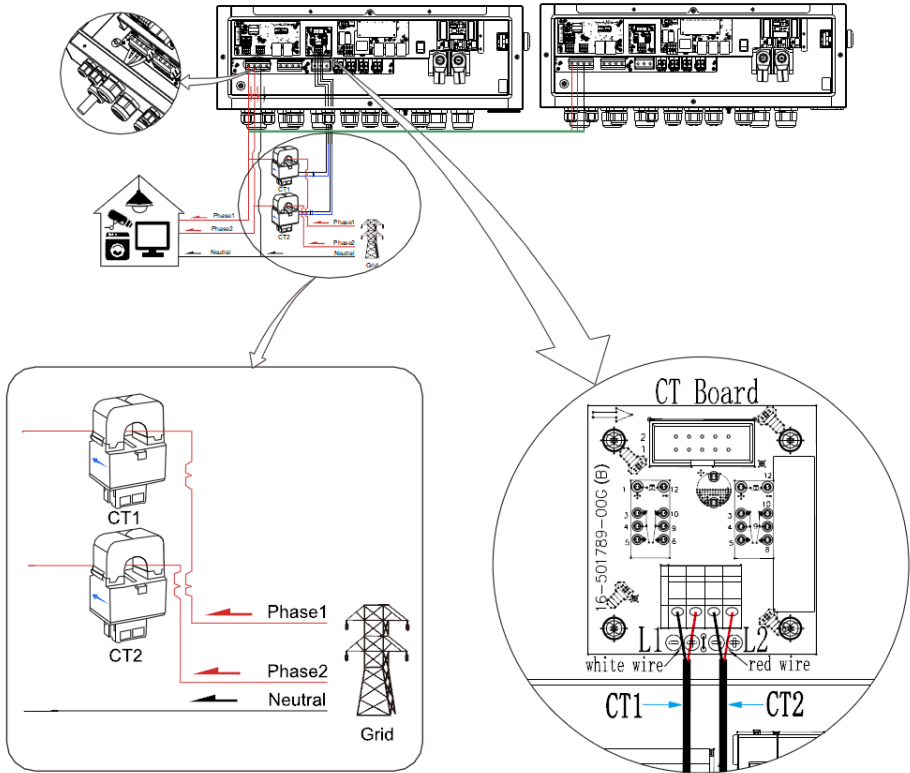

NOTE:

1. The arrow is printed on the CT sensor. Please check the direction of the CT sensor.
2. CT Board is printed with '+' and '-'. Please connect the red wire of the CT sensor with '+' and the white wire with '-'

Step 2: Power on all inverters, wake up the LCD and modify the Settings. Enter LCD setting #13 and set up as any Grid-tie with backup mode. The CT will not be enabled if not setting to grid-tie with backup.

13	Operation Mode	Grid-tie with backup	PV power can feed-in back to grid, provide power to the load and charge battery.
		13	

Step 3: Set up LCD setting #36 on parallel inverters. Enter LCD setting #36 and select "parallel 50A" or "parallel 200A" based on your CT specifications. **Be sure to enable #36 external CT function on the one inverter with CT connected and set up "disable" on the remaining inverters.** Otherwise, it will cause CT function not working during parallel operation.

36	External CT function	Disable (default) 36 CTd	
		SINGLE 50A 36 S 1G50	PARALLEL 50A 36 PAL50
		SINGLE 200A 36 S 1G200	PARALLEL 200A 36 PAL200



36	External CT function	Disable (default) 36 CTd	
		SINGLE 50A 36 S 1G50	PARALLEL 50A 36 PAL50
		SINGLE 200A 36 S 1G200	PARALLEL 200A 36 PAL200

IMPORTANT ATTENTION :

If applying CT function during parallel operation, it only needs one inverter from parallel system connected to CT sensor. Be sure to enable #36 external CT function on the one inverter with CT connected and set up "Disable" on the remaining inverters. Otherwise, it will cause CT function not working during parallel operation.

Step 1. Refer to "Single commissioning" or "Parallel commissioning" for wiring and enable CT function.

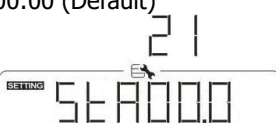
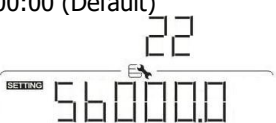
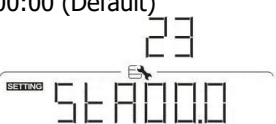
Step 2. Set the following four options. The machine has a function of setting two periods of time. If you only need to set a certain time of the day, please set the same time on LCD setting #21, 22 and #23, 24.

21	Start charging time for first duration of AC charge	00:00 (Default) 	The setting range of start charging time for AC charger is from 00:00 to 23:00. Increment of each click is 1 hour.
22	Stop charging time for first duration of AC charge	00:00 (Default) 	The setting range of stop charging time for AC charger is from 00:00 to 23:00. Increment of each click is 1 hour.
23	Start charging time for second duration of AC charge	00:00 (Default) 	The setting range of start charging time for AC charger is from 00:00 to 23:00. Increment of each click is 1 hour.
24	Stop charging time for second duration of AC charge	00:00 (Default) 	The setting range of start charging time for AC charger is from 00:00 to 23:00. Increment of each click is 1 hour.

NOTE:

With CT function enabled, if LCD setting 21, 22, 23, and 24 are all set to 00, it means that no grid power charging will be used. If only 21 and 22 are modified and 23 and 24 remain set to 00, it means that grid power charging will be used all day. Similarly, if only 23 and 24 are modified and 21 and 22 remain set to 00, it also have the same result. For example, if you want to charge from 18:00 to 23:00 using grid power, set 21 and 23 to 18:00 and 22 and 24 to 23:00.

Appendix III: The Generator Operation Guide

Through the generator port, the inverter can realize multiple groups of redundant backup power supply. In the absence of grid or solar power, users have the option of using a generator to charge the battery and power the load. Follow below steps to activate this function.

Step 1. Turn on the inverter and enable generator port function in LCD program #39 (Select "GEN ").

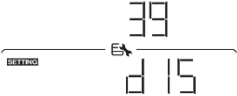
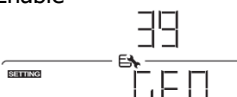
39	Generator port Function	Disable(default) 	If selected, the input of generator port will be disabled.
		Enable 	If selected, generator port will be activated.

After setting, " **APL** " icon will flash on LCD display.

Step 2: You need to turn on the AC output of the inverter. The generator can only be used in battery mode. Once generator port function is activated and power input of generator enter the inverter, " **APL** " icon will be illuminated and input voltage/input frequency will show on the LCD display.

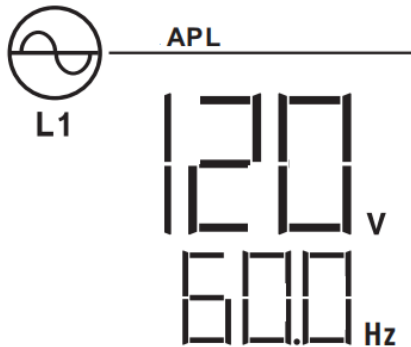

Note:

1. When the generator is in use, the inverter will force the battery to charge.
2. When the generator is in use, the maximum charging current of the inverter will be limited to 100A, and the user can choose a lower charging current by setting LCD #05.
3. The generator will be used when the power grid is lost. If the power grid is restored, the generator will stop being used.

Appendix IV: Rapid Shutdown Operation

1. Working principle

When an emergency occurs that requires the inverter to disconnect the power supply and cut off output immediately. The utility port, output port and generator port of the inverter can be disconnected through the internal relay of the inverter. The DC-DC circuit on the battery port can stop working and the transformer inside the inverter can isolate the battery.

While stopping the power supply at the PV port, it will need the “transmitters” of the inverter sends a signal to inform the switch off and the receiver is located in the path between the PV port of the inverter and the PV panel. “Transmitters” is not standard accessory in the package and needs to be purchased separately.

The arrow in following chart shows the installation position of the “transmitters” inside the inverter.

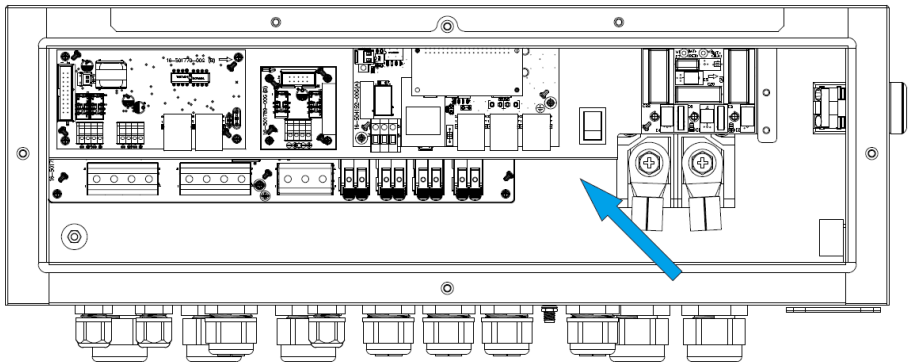

2. The method to trigger the inverter rapid shutdown

Step 1: Complete the installation of the RSD switch with all power supplies cut off from the inverter.

- 1) You need a self-locking switch as RSD switch, and the corresponding wire. The cable size is recommended to be #20.

2) Open the wiring cover of the inverter and locate the communication board.

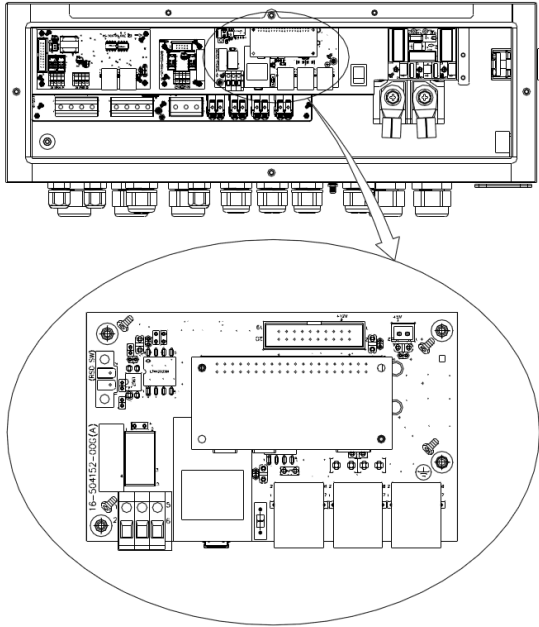

3) Connect the RSD switch to the RSD SW port through the inverter communication bushing.

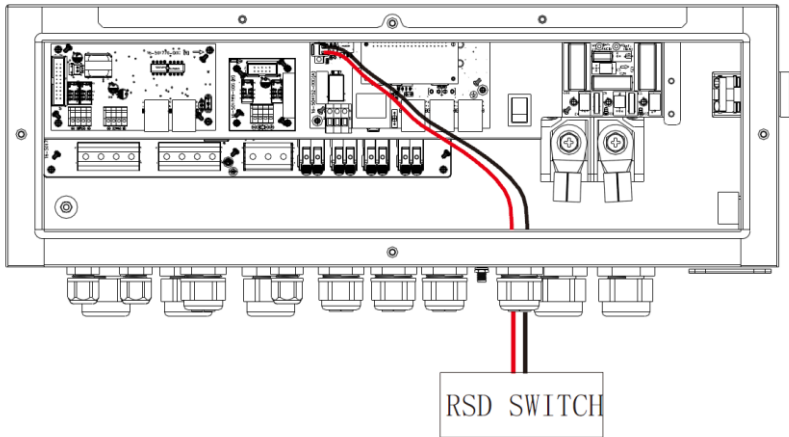

Step 2. After the inverter is powered on, set up LCD setting #41 as "enable".

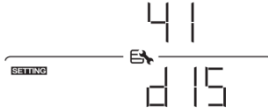
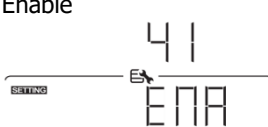
41	Rapid Shutdown Function (optional, refer to Appendix VI for the details)	Disable(default) 	If selected, RSD dry contact will be idle.
		Enable 	If selected, close the RSD dry contact, the machine will shut down the output and stop working. Disconnect the dry contact and the machine will return to its pre-closure state.

Step 3. Close the RSD switch to trigger the inverter rapid shutdown.

When RSD function is triggered, the inverter LCD will display alarm code W18. The inverter internal utility relay, output relay and generator relay will be disconnected, the BAT DC-DC circuit will stop working.

If there is a transmitter installed, it will stop sending pulse signals to inform the receiver that the photovoltaic panel switch needs to be disconnected. The inverter will turn off all power except SPS.

Step 4. Open the RSD switch to relieve the inverter rapid shutdown.

When the RSD switch is open, the alarm code W18 displayed in the LCD will disappear, and the inverter will resume normal operation.

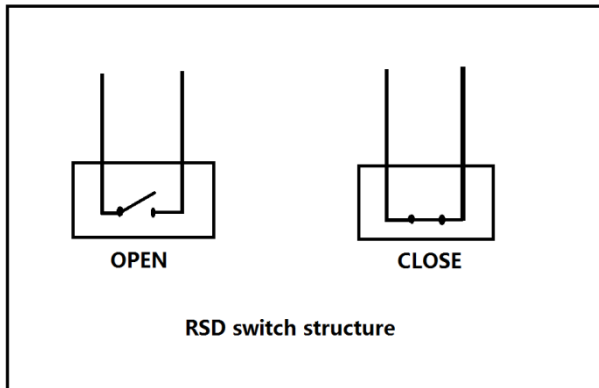

Appendix V: AC Coupling Wiring and Operation

1. Introduction

The grid-tie inverter does not work properly in areas where the grid is unstable. In this case, you can connect the grid-tie inverter to the generator port of hybrid inverter. When LCD setting #38 AC coupling function is enabled, the generator port of hybrid inverter can act as a stable grid. Grid-tie inverter power will be used to power load and then charge battery, and feed to the grid at last.

2. Specification of Grid-tie inverter

- A): Rated output of Grid-tie inverter not exceed 6000W.
- B): The Grid-tie inverter is with overfrequency derating function.

3. Connection with Grid-tie inverter

A) The 240V single-phase grid-tie inverter is connected to the L1-L2 terminal of generator input in the hybrid inverter. The N terminal does not need to be connected.

B) The 120V split-phase grid-tie inverter is connected to the L1-L2-N terminal of generator input in the hybrid inverter. The N terminal must be connected.

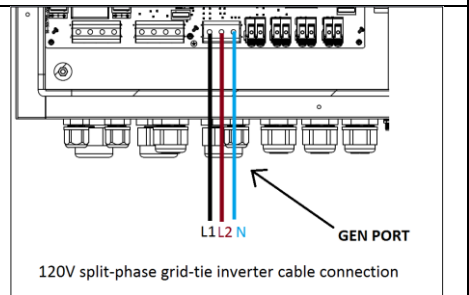
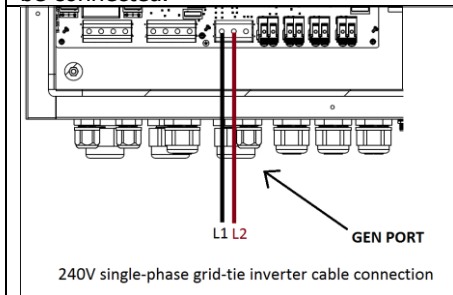

4. Operation

Step 1: Power off hybrid inverter first. Connect utility output of grid-tie inverter to generator input of hybrid inverter.

Step 2: Connect hybrid inverter to a battery and power on the inverter. Set LCD setting #38 (AC coupling) of hybrid inverter to enable.

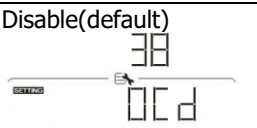
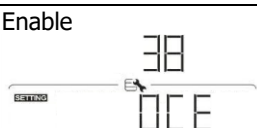
38	AC coupling (Refer to Appendix V for the detail)	Disable(default) 	If selected, there is no output voltage from generator port of hybrid inverter.
		Enable 	If selected, there is output voltage from generator port of hybrid inverter.

NOTE:

1. AC coupling is only available in single mode.
2. Hybrid inverter must be connected to a battery and the maximum battery charging current is not less than 150A.
3. It's not allowed to have AC coupling function and CT mode at the same time. It's required to set LCD setting #36 (External CT function) as "disable" before AC coupling operation.

Appendix IV: The Wi-Fi Operation Guide

Brief Introduction

“Energy-Mate” is an intelligent software developed specifically for remote management and monitoring of inverters, aiming to provide users with comprehensive, real-time operating status monitoring and remote control of inverters.

Download Methods

The download method for Android users is to search for “Energy-Mate” on Google Play or scan the QR code to download; The download method for iOS users is to search for “Energy-Mate” on the App Store or scan the QR code to download.

Energy-Mate



Registration account and Login

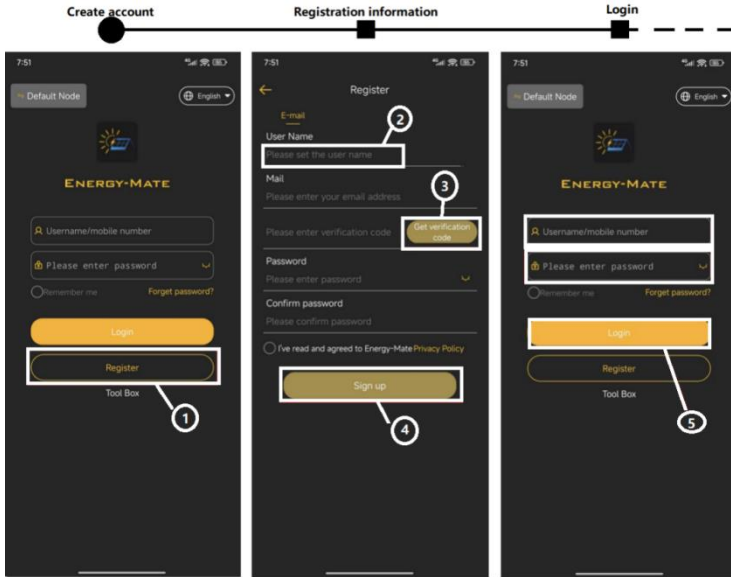

Add Datalogger

Enter the "Datalogger" list interface and click the  icon in the upper right corner. After scanning the nearby Bluetooth, find the SN number of the device.

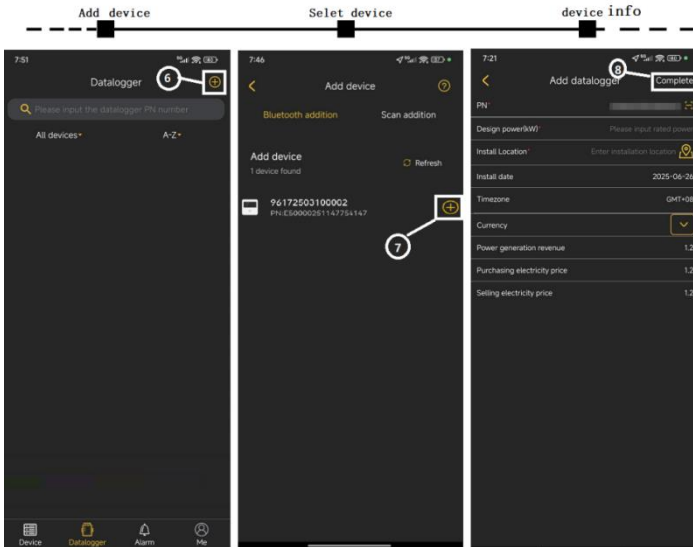

Note: find the SN number of the device for the “select device”

Datalogger Distribution Network

The APP supports two types of networking modes, and users can choose according to their Datalogger models:

- Use with Bluetooth module: Bluetooth networking
- Use without Bluetooth module: Wi-Fi networking

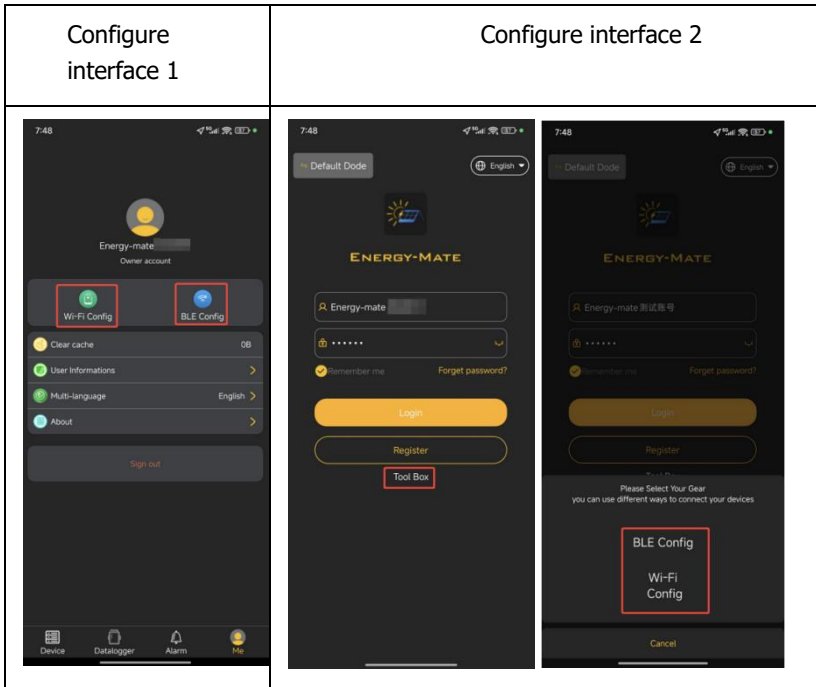

Note: You can choose Configure interface 2 for network distribution without registering an account.

1. The router does not support 5G band. Please use the router with 2.4G band.
2. Make sure the router password is correct.
3. Check the distribution network results.
4. If the network is successfully configured, you can see the device data in about 5 minutes.
5. If the network configuration fails, troubleshoot the problem according to the actual page repair suggestions.

Bluetooth distribution network

- Bluetooth pairing (Bluetooth networking): The APP scans the nearby Bluetooth device (make sure your phone is turned on "Bluetooth"), and then selects the Bluetooth device with the name PN number and clicks to connect.
- Enter the name and password of the router you want to connect to, or click the signal icon to view the best router in your nearby network for connection.

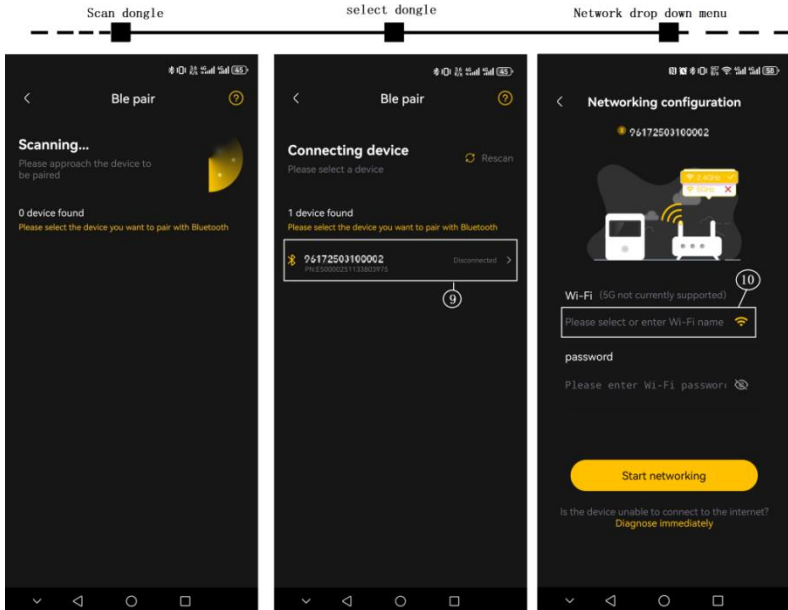

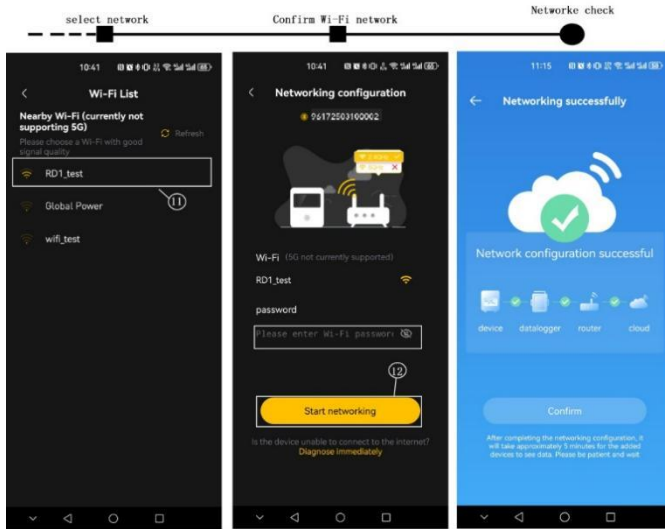

Wi-Fi distribution network

1. On your Smart Phone or Computer go to: Settings → Wi-Fi → Select the E50#### network → Password= 12345678
2. Open the APP → Me → Wi-Fi config → Network settings
3. Select Home network and input personal credentials.
4. Click "setting" to save your information.
5. On your Smart Phone or Computer go to: Settings → Wi-Fi → Select the E50#### network → Password= 12345678
6. Click "Diagnose" to check the network connection.

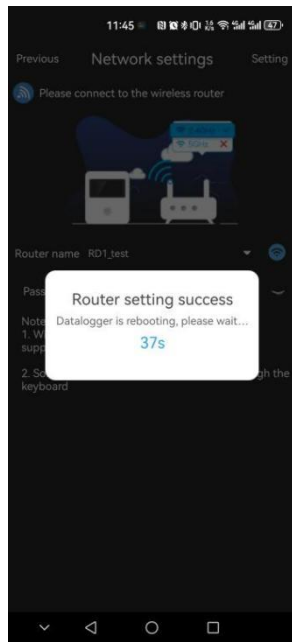
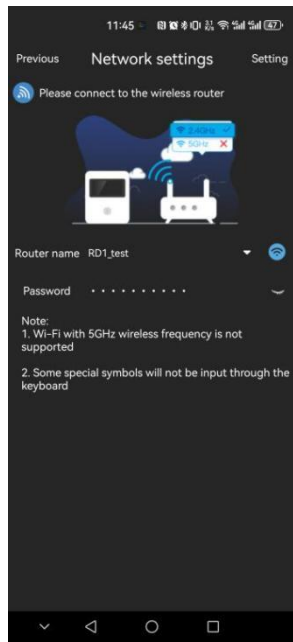
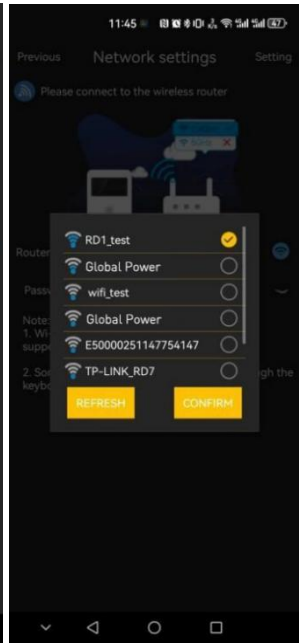
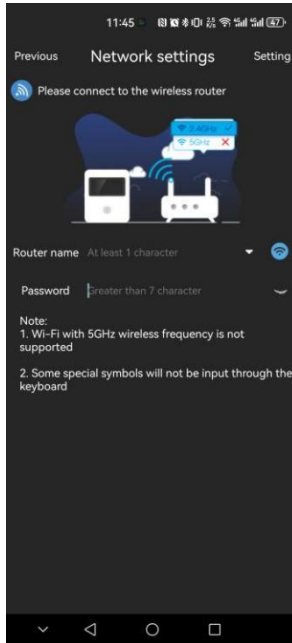

Appendix V: Solar Assistant Operation Guide

SolarAssistant is software that is integrated into the inverter system via a Raspberry PI which can monitor and control the inverter and the battery packs. The application can be accessed from a web browser or the Android/iPhone app via local network or the internet.

System hardware Connection

1. Use the enclosed BMS communication cable to connect the BMS port to the RS485 port of the Battery, this connection will enable the inverter to read the battery SOC and perform operation mechanisms based on SOC control.
2. Use the enclosed BAT communication cable to connect the BAT port to the RS485A port of the 1st battery in a paralleled battery packs group, follow the battery manual instruction to make sure that all the battery packs are paralleled correctly with correct DIP switches allocated on each battery, this connection will enable the Solar Assistant to read the detailed information of each battery packs on Solar Assistant website.
3. Turn on the Power switch of the Solar Assistant.

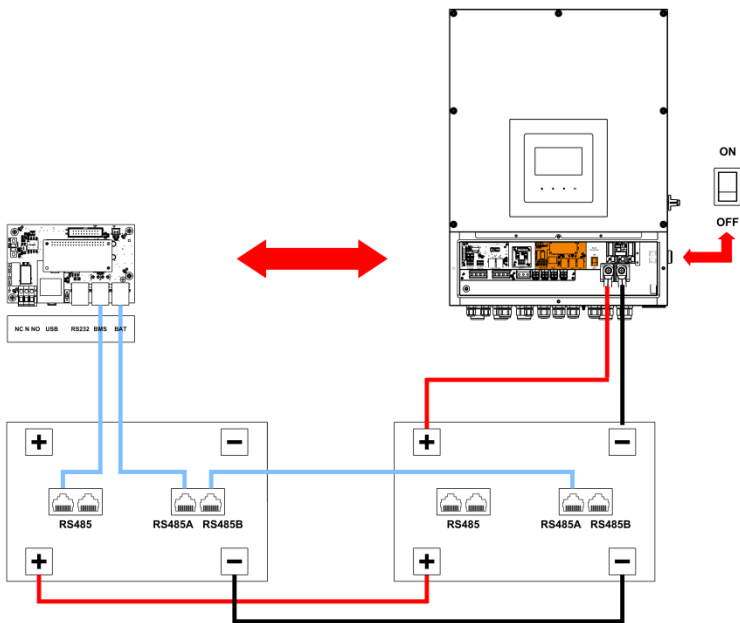

Register as a Solar Assistant user.

Go to <https://solar-assistant.io/register> , Fill the required personal information,click"Register" to complete user registration. After register, sign in.

solar-assistant.io/register

solar assistant Sites Account Shop Help Sign in Register

Register

Email myname@yourdomain.com

First name my

Last name name

Password *****

Password must have at least:

- 8 characters
- lower case character
- upper case character
- one digit or punctuation character

Accept [terms and conditions](#)

Register

Internet connection

Connect to WiFi access point

The device will start a WiFi access point. Use your laptop, tablet or mobile phone to connect to it:

SSID: **SolarAssistant**

Password: **solar123**

Open the URL below: <http://10.0.0.5>

NB: If you are using your mobile phone or tablet you will need to **turn off your mobile data** to ensure it is using WiFi instead of mobile data.

Give the device your WiFi credentials

Once you have the device web page open, you will be taken to the configuration page. Enter your Wifi SSID and password and click submit.

WiFi network

Select network: Home WiFi (78%)

Password:

Cancel Submit

Network status

Internet		Down
eth0		Down
wlan0	10.0.0.5	Up

Switch your WiFi over to the same network the device is trying to connect to.

Find device on local network

Open <https://solar-assistant.io/sites/local> to find your device on your local network.

NB: If the device failed to connect to your WiFi network, it will start the WiFi access point again. Go back to step **1. Connect to WiFi access point.**

Select your region and register your site.

By registering your site you can easily access it remotely.

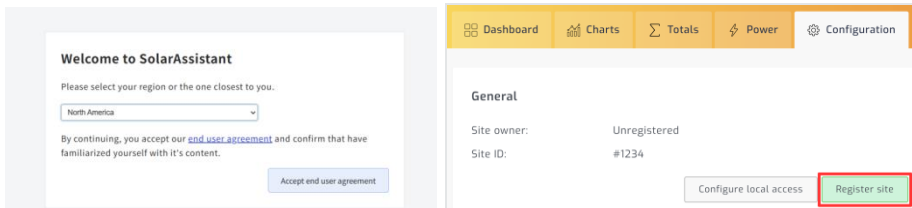

Configure the devices.

Click the **Configuration** tab to configure inverter and battery, and PV power. For Inverter, Select Model as **Global Power**, Connection as **Integrated Inverter**, For Battery, Select the right battery type(Consult the battery seller), select Battery Connection as **SC1 Serial Channel**.

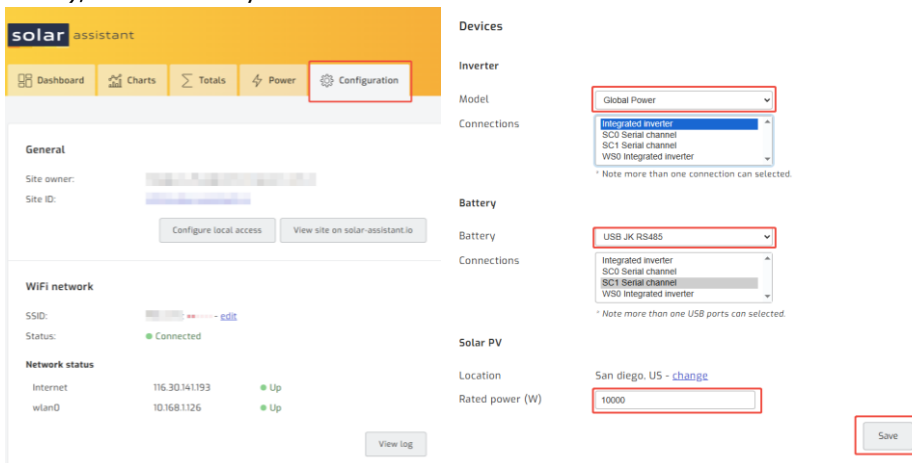

You can also click "Advance" button to enter advance setting of the PV,Grid,Battery, Battery Capacity,etc. **Make sure to select Yes for "Allow passive reading"**. Save the setting and click the green "Connect" button to complete the basic configuration.

Battery - JK R54B5

Allow passive reading Yes No
automatically activated if any data is received when the connection starts.

Capacity kWh
Battery capacity above is only used when not readable from battery or inverter.

Save

Solar PV

Location
Rated power (W)

Advanced

Connect

Once both the Inverter and the Battery are connected successfully, a green dot and green Connected sign will show after Status. Now you can click the "Dashboard" tab to view the status of the whole system.

The screenshot shows the Solar Assistant interface. On the left, there are configuration panels for the Inverter and Battery. The Inverter status is 'Connected' and the Battery status is also 'Connected'. The main dashboard on the right displays various system metrics: Inverter Solar/Battery mode, Grid 242V, Solar PV 23.2kW, and Battery 71% SOC. There are also charts for PV Today and an Overview chart.

The inverter daily frequently used settings such as inverter work mode, Charger, Grid export switch, Battery BMS type, Battery charger, Battery SOC control etc are programmable on the Solar assistant. To program, Click the **Configuration** tab, scroll down to **Devices-inverter**, click the **"Settings"** next to **Status -Connected** to enter programming page.

The screenshot shows the Solar Assistant Configuration page. The Configuration tab is selected. The page shows a 'General' section with fields for Site owner and Site ID. Below this, there are buttons for 'Configure local access' and 'View site on solar-assistant.io'. The 'Configuration' tab is highlighted in the top navigation bar.

Devices

Inverter

Model

Connections

Status Connected Settings

Click "edit" of each parameter section to program your desired setting.

Dashboard Charts Totals Power Configuration

Configuration > Inverter 1

Specification	
Driver	Global Power
Monitoring connection	Direct cable
Serial number	96192510100012
Firmware version	→ 15.01
Model number	12
Nominal battery voltage	48.0V
Expected AC input voltage	120V
Max AC input current	66.6A
Max AC output current	66.6A
Max AC output power	15.0kW

Power management edit	
Work mode	→ Off-grid
PV charger	Enabled
AC charger	Enabled
Load supply if PV available	→ Solar/Grid/Battery
Load supply if PV unavailable	→ Battery/Grid
Feed to grid	Disabled
Battery feed to grid if PV available	Disabled
Battery feed to grid if PV unavailable	Disabled

Battery edit	
Battery type	→ Pylontech BMS
Battery activation	Disabled
Shutdown battery capacity	30%
Back to battery capacity after shutdown	40%
To grid battery capacity	0%
Back to battery capacity	0%
Battery float charge voltage	56.0V
Battery absorption charge voltage	58.0V
Max charge current	50.0A
Max grid charge current	2.0A
Max generator charge current	0A

Input/output edit	
AC output voltage	120V
Wide AC input range	Disabled
Generator as AC source	Disabled
Generator port	→ Disabled
External CT relay type	→ Disabled
Rapid shutdown	Enabled

Pairing of multiple Inverters

If you have multiple inverters connected in parallel, Follow the follow diagram to connect the Solar assistant with the battery packs. Use the enclosed BMS communication cable to connect the BMS port on the master inverter to the RS485 port of the Battery, this connection will enable the inverter to read the battery SOC and perform operation mechanisms based on SOC control.

Use the enclosed BAT communication cable to connect the BAT port on the master inverter to the RS485A port of the 1st battery in a paralleled battery packs group, follow the battery manual instruction to make sure that all the battery packs are paralleled correctly with correct DIP switches allocated on each battery, this connection will enable the Solar Assistant to read the detailed information of each battery packs on Solar Assistant website.

Turn on the Power switch of the Solar Assistant in all inverters.

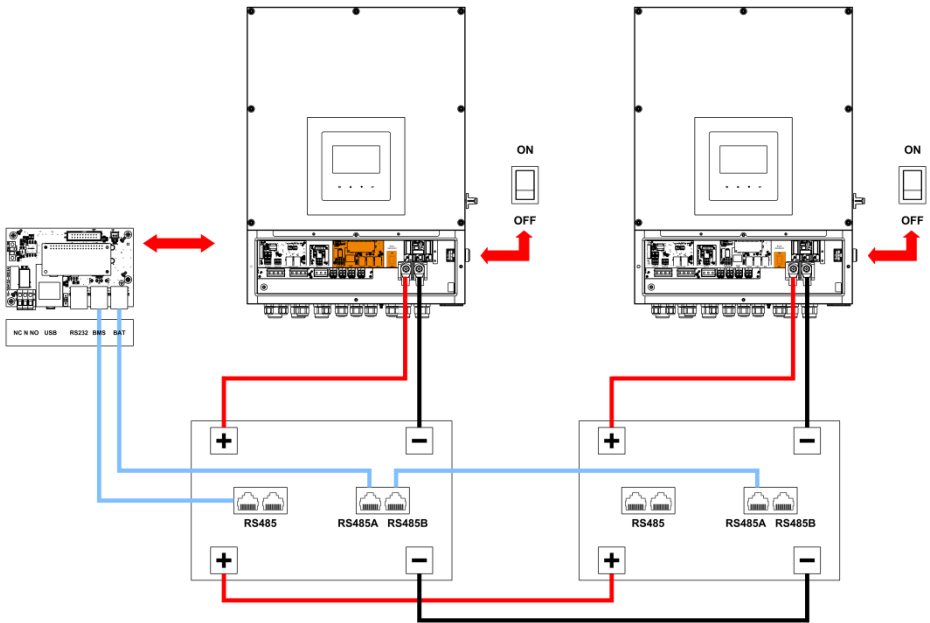

Follow the guide before to configure the Solar assistant for the master inverter firstly.

Click the **Configuration tab**, scroll down to **Pairing**, click **"Configure"**

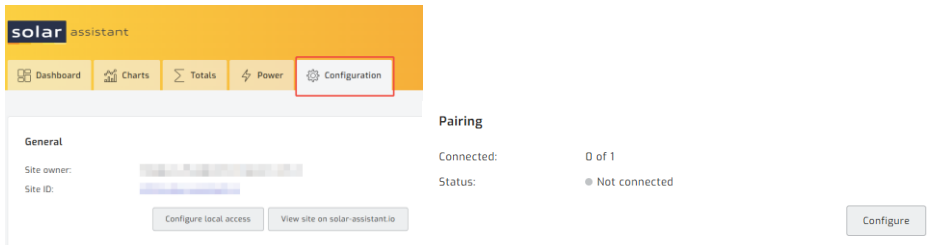

The rest sites will list up, Click **"connect"**.

solar assistant

Dashboard Charts Totals Power Configuration

[Configuration](#) > Pairing

Site	Name	IP address	Status
#40949	rd1	10.168.1.126	● Not connected connect

Click **"Pair"** in the pop up window of "Are you sure you want to pair this device to **XXX site**?" to complete the pairing.

solar assistant

Dashboard Charts Totals Power Configuration

[Configuration](#) > [Pairing](#) > Connect

Are you sure you want to pair this device to **rd1-2**?

Cancel **Pair**

The status will update as "connected" and Pairing log will display at the right side of the window.

solar assistant

Dashboard Charts Totals Power Configuration

[Configuration](#) > Pairing

Site	Name	IP address	Status
#40949	rd1	10.168.1.126	● Connected logout

Pairing log
[Tue Mar 10 09:31:12] [network peers]: Paired with site: #40949.